

# **STACKABLE ALL-IN-ONE ESS**

HYX-H6K-HTA / HYX-H9K-HTA /  
HYX-H12K-HTA / HYX-H15K-HTA

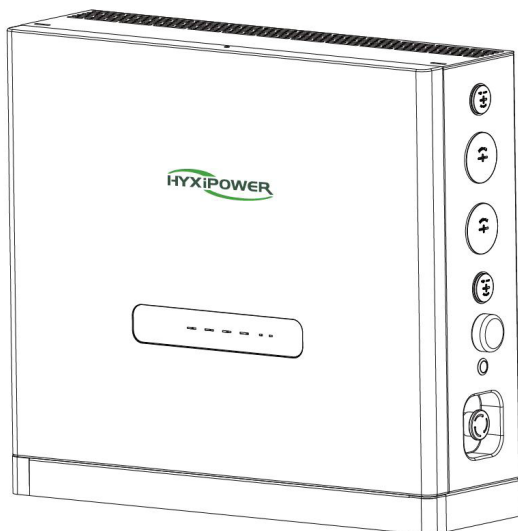

Carefully read this battery system user instructions before using.  
Read and save these instructions.



© 2024 ZHEJIANG HYXI TECHNOLOGY CO., LTD. All rights reserved.

This document cannot be copied fully or partially, transferred, or distributed in any form without the prior written permission of ZHEJIANG HYXI TECHNOLOGY CO., LTD (hereinafter referred to as "HYXiPOWER").

## TRADEMARKS



and other HYXiPOWER trademarks are the trademarks or registered trademarks of HYXiPOWER. All other trademarks mentioned herein are the properties of their respective owners.

# Contents

<b>Preface</b> .....	<b>1</b>
Overview .....	1
Scope of application.....	1
For readers .....	1
Use of the manual.....	1
Use of symbols.....	2
<b>1 Safety Precautions</b> .....	<b>3</b>
1.1 General Safety .....	3
1.2 Public Grid.....	3
1.3 Photovoltaic String.....	3
1.4 Inverter .....	4
1.5 Personnel Requirements.....	4
<b>2 Product Overview</b> .....	<b>5</b>
2.1 Product Description .....	5
2.2 Photovoltaic Hybrid System .....	5
2.2.1 Grid Forms Supported by Hybrid Inverters .....	6
2.3 Nameplate Description.....	6
2.4 Product Appearance .....	7
2.4.1 Symbol Description .....	7
2.5 System Model.....	7
2.6 Dimensions.....	8
2.7 LED Indicator Panel.....	8
2.7.1 LED Indicator Status Description .....	8
2.8 Functional Description .....	9
<b>3 Inspection and Storage</b> .....	<b>10</b>
3.1 Unpacking and Inspection.....	10
3.2 Inverter Storage.....	11
<b>4 Mechanical Installation</b> .....	<b>12</b>
4.1 Installation Precautions.....	12
4.2 Unpacking for Confirmation .....	12
4.3 Pre-Installation Preparation.....	12
4.3.1 Installation Tools .....	12
4.3.2 Installation Environment.....	13
<b>5 Electrical Connection</b> .....	<b>16</b>
5.1 Electrical Connection Preparation.....	16

5.2	Grounding Connection .....	16
5.3	PV Side Connection .....	17
5.4	Selecting New Installation or Classic Installation .....	18
5.4.1	New Installation.....	18
5.4.2	Classic Installation.....	19
5.5	Selecting WIFI Module or 4G Module.....	20
<b>6</b>	<b>Human-Computer Interaction .....</b>	<b>21</b>
6.1	Installing the App.....	21
6.2	APP User Manual.....	21
6.3	System Debugging .....	21
<b>7</b>	<b>Operation.....</b>	<b>22</b>
7.1	Pre-Operation Inspection.....	22
7.2	System Startup .....	22
7.3	Grid-Connected Inverter Operation .....	23
7.4	Inverter Shutdown .....	23
7.5	Inverter Removal .....	24
7.6	Ripple control.....	25
7.7	Disposal of Inverter .....	25
7.8	Routine Maintenance and Overhaul.....	26
7.8.1	Maintenance Precautions.....	26
7.8.2	Routine Maintenance .....	27
7.9	Function Settings Explanation.....	28
7.9.1	Work Mode.....	28
7.9.2	Export Control.....	28
7.9.3	Retrofit.....	28
<b>8</b>	<b>Appendix.....</b>	<b>30</b>
8.1	Technical Parameter.....	30
8.2	Alarm Code .....	31
8.3	Quality Assurance .....	35
8.4	Contact Information .....	36

# Preface

HYXiPOWER storage high voltage stacker can provide a variety of operating modes according to different needs, self-generation, peak-shaving, battery priority, etc.

## Overview

This manual provides the user with product information, detailed installation and use, troubleshooting and daily maintenance of the PV storage inverter.

It does not contain all information about the PV system.

To ensure the proper installation and use of the inverter and its superior performance, before handling, installation, operation and maintenance of the inverter, please read the instruction manual in detail and follow it.

Please read the operating instructions in detail and follow all safety precautions in the instructions.

## Scope of application

This manual is intended for the following devices:

- HYX-H6K-HTA
- HYX-H9K-HTA
- HYX-H12K-HTA
- HYX-H15K-HTA

The inverter module power size depends on battery number:

BAT Number	System Power Size
2	6kW
3	9kW
4	12kW
5	15kW

## For readers

This manual is intended for professional technicians who need to install, operate and maintain the inverter and for users who need to check the inverter parameters.

All installation operations must be carried out by professional technicians and only by professional technicians.

## Use of the manual

Please read the manual carefully before using the product, the content of the manual will be updated and corrected, but it is inevitable that there is a slight discrepancy or error with the actual product. Users should refer to the actual product purchased and obtain the latest version of the manual by downloading from [www.hyxipower.com](http://www.hyxipower.com) or through sales channels.

The latest version of the manual is available for download at or through sales channels.

## Use of symbols

In order to ensure the safety of the user's person and property when using the product, relevant information is provided and highlighted using the following symbols.

### **DANGER**

- Indicates a high potential hazard that, if not avoided, could result in death or serious injury.

### **WARNING**

- Indicates a moderate potential hazard that could result in death or serious injury if not avoided.

### **CAUTION**

- Indicates a low potential hazard which, if not avoided, could result in moderate or minor injury.

### **NOTICE**

- Indicates a potential risk which, if not known to be avoided, could result in the equipment not functioning properly or in property damage.

# 1 Safety Precautions

## 1.1 General Safety

### NOTICE

- The "DANGER", "WARNING", "CAUTION", and "NOTICE" items in the manual do not include all safety precautions that should be observed. All work should be carried out in combination with the actual situation on site.
- This equipment should be used in an environment that meets the requirements of design specifications, otherwise it may cause equipment failure, and the resulting equipment functional abnormalities or component damage, personal safety accidents, property losses, etc., are not within the scope of equipment quality assurance.
- The installation, operation and maintenance of the equipment should comply with local laws, regulations and codes. The safety precautions in the manual are only supplementary to the local laws and regulations.
- If an external residual current device (RCD) (type A is recommended) is mandatory, the switch must be triggered at a residual current of 300 mA (recommended). RCD of other specifications can also be used according to local standard.

## 1.2 Public Grid

### NOTICE

- All electrical connections must meet local and national electrical standards.
- The inverter may only be connected to the grid with the permission of the local electricity authority.

## 1.3 Photovoltaic String

### DANGER

- When performing electrical connection work, you must wear personal protective equipment.
- Use a multimeter DC block to measure the positive and negative DC cable polarity to ensure that the polarity is correct; and the voltage is within the allowable range.
- After the DC cable is connected, please make sure that the cable is tightly connected and not loose.

## 1.4 Inverter

### DANGER

- Before plugging or unplugging the PV connector or AC connector, please use a multimeter to measure to make sure there is no voltage or current.
- Make sure that the voltage and frequency of the grid connection point are in accordance with the grid connection specification of the inverter.
- Do not open the inverter housing when the inverter is operating or energized to protect personnel and property safety.
- After removing all electrical equipment and disconnecting the inverter, wait at least 5 minutes for the internal capacitors to discharge.
- The protective ground of the inverter must be securely connected and, for multiple inverters, ensure that all inverters are connected to the protective ground.
- When multiple inverters are installed, ensure that all inverter enclosures are connected equipotentially to the protective ground. Install the equipment first.
- The protective ground is installed first; the protective ground is removed last when the equipment is dismantled.

### WARNING

- After the inverter is installed, labels and warning signs shall be clearly visible, and obscuring, altering or damaging them is prohibited.
- After the inverter is shut down, there is still a risk of burns, after the inverter has cooled down, wear protective protective gloves before operation.

## 1.5 Personnel Requirements

### NOTICE

- Only qualified professionals or trained personnel are allowed to install, operate and maintain the equipment.
- The personnel who operate the equipment, including operators, trained personnel, professionals should have the special operating qualifications required by the local country, such as high voltage operation, special equipment operation qualification, etc.

# 2 Product Overview

This chapter mainly introduces the appearance of the grid-connected inverter, packaging accessories, nameplate, technical parameters, etc.

## 2.1 Product Description

HYX-HK-HTA is a three-phase stackable all-in-one inverter module, the main function is to convert the DC power generated by the PV string into AC power for load use, storage to the battery and output to the grid.

This paper mainly covers the following system models.

- HYX-H6K-HTA
- HYX-H9K-HTA
- HYX-H12K-HTA
- HYX-H15K-HTA

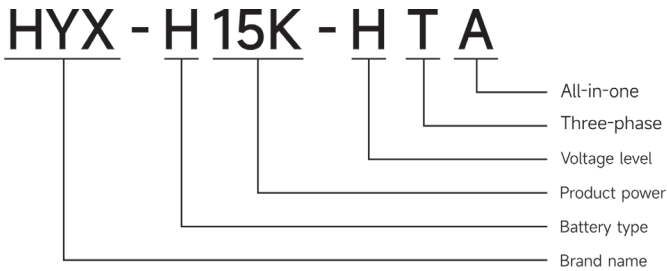

## 2.2 Photovoltaic Hybrid System

The PV hybrid system is composed of PV modules, inverter, battery, meter, load and grid. The inverter is the core component of the PV hybrid system.

The solar energy is transformed into DC energy by the PV modules, and then transformed into sinusoidal AC energy with the same frequency and phase as the public grid by the hybrid inverter.

The hybrid inverter is used by the crystalline silicon solar cell set without grounded positive and negative poles as the DC input, battery pack as DC input.

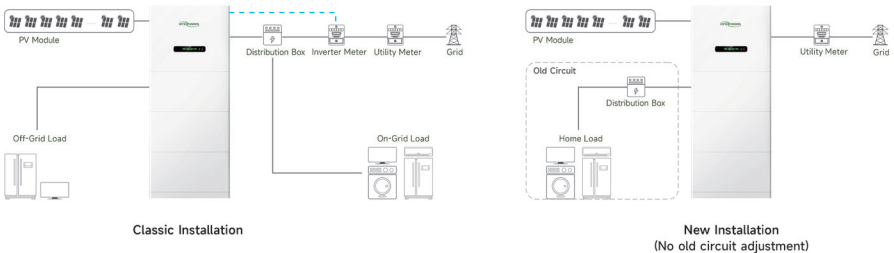

### 2.2.1 Grid Forms Supported by Hybrid Inverters

The grid forms supported by hybrid inverters are TN-S, TN-C, TN-C-S, TT.

The voltage requirement of N to PE is less than 30V.

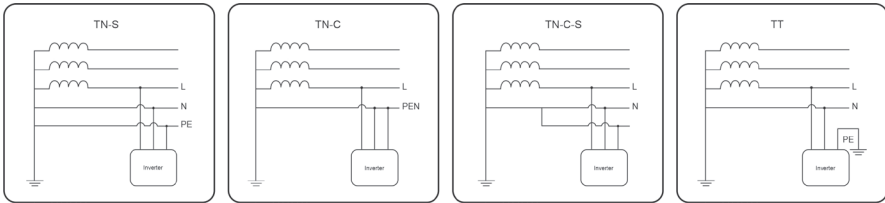

**WARNING**

- The inverter is only applicable to the hybrid system described in this document.
- Since the inverter is transformerless type, it is required that both the positive and negative terminals of the PV module cannot be grounded, otherwise the inverter will otherwise the inverter will not operate normally.
- During the installation and operation of the inverter, please make sure that the positive or negative pole of the PV module will not be short-circuited to the ground, if short-circuited, it may if short-circuited, it may cause the inverter AC/DC short circuit, resulting in equipment damage, and the resulting damage will not be covered by the warranty.

**CAUTION**

- For TT type grids, the N line voltage to ground must be less than 30V.
- Never connect local loads between the inverter and the AC circuit breaker, such as household appliances, lighting loads, etc.

### 2.3 Nameplate Description

<b>HYXPOWER</b>	
Model: HYX-H5K6-HS Product: Single Phase Hybrid Inverter	
<b>Input (DC)</b>	
Max. Input Voltage:	d.c. 660V
MPPT Voltage Range:	d.c. 60-540V
Max. Current per MPPT:	d.c. 2*16A
Max. PV/Collector max.:	d.c. 2*30A
<b>Battery(DC)</b>	
Battery type:	Lithium-ion
Battery Voltage Range:	d.c. 60-450V
Max. Charge/Discharge Current:	d.c. 55A
<b>On-grid(AC)</b>	
Rated Grid Voltage:	L/N/PE, a.c. 220/230/240V
Rated Grid Frequency:	50/60Hz
Rated Output Power:	3600W
Max. Continuous Current:	a.c. 16.0A
Max. Continuous Apparent Power:	4000VA
<b>Back-up(AC)</b>	
Nominal voltage:	a.c. 220/230/240V
Frequency:	50/60Hz
Max. Continuous Current:	a.c. 16.0A
Rated Output Power:	3600VA
Max. Continuous Output Apparent Power:	4000VA
<b>General Data</b>	
Power Factor:	0.8 leading/0.8 lagging
Operating Temperature Range:	-25 to +50°C
Protection Degree:	IP55
Protection/OVC:	Class II/DC II/AC III
Zhejiang Hyl Technology Co., Ltd.      support@hyxpower.com Add: 9/F, Building 5, Jiaan Commercial Center, Zhujiang Road, Bin-shi-district, Shaoxing City, Zhejiang Province, China. 313004	

Hyxi trademarks, product types and product models.

Product technical parameters.

Safety symbols and certification marks.

Contact information and serial numbers.

## 2.4 Product Appearance

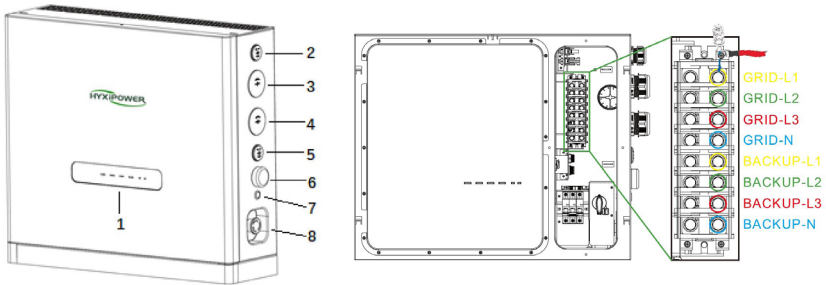

No.	Name	Description
1	LED indicator panel	Indicates the current operating status of system
2	PV connection port	Port for PV cable
3	GRID connection port	Port for GRID cable
4	BACKUP connection port	Port for BACKUP cable
5	COM connection port	Port for COM cable
6	DCS signal booster	Avoid signal blocking
7	POWER button	Shutdown the whole system
8	Emergency stop button	INV-BAT Power

### 2.4.1 Symbol Description

Symbol	Description
	Disconnect power for at least 5 minutes before servicing the inverter.
	Hot surface! Do not touch the inverter housing while it is in operation.
	Beware of electric shock!
	Risk of danger!
	Read enclosed document.
	CE mark. The inverter complies with the regulations of CE.
	Do not dispose the inverter together with the household waste.
	Grounding point.

## 2.5 System Model

System Model	BAT number	Product Name	Rated Output Power (W)
HYX-H6K-HTA	2	Stackable all-in-one	6000
HYX-H9K-HTA	3	Stackable all-in-one	9000
HYX-H12K-HTA	4	Stackable all-in-one	12000
HYX-H15K-HTA	5	Stackable all-in-one	15000

## 2.6 Dimensions

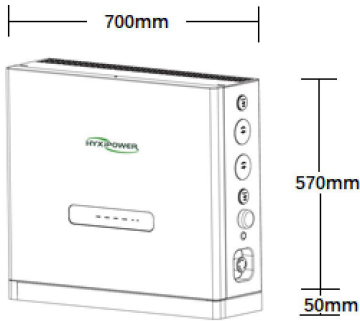

## 2.7 LED Indicator Panel

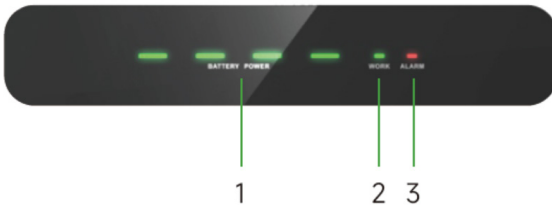

### 2.7.1 LED Indicator Status Description

No.	Indicator	Status	Description
1	SOC Green	Capacity	██████
2	WORK Green █	ON-GRID	ON
		OFF-GRID	ON 0.5s, OFF 0.5s
		Standby	ON 0.5s, OFF 1.5s
		Shutdown	OFF
3	ALARM Red █	ON-GRID	ON
		OFF-GRID	ON 0.5s, OFF 0.5s
		Standby	ON 0.5s, OFF 1.5s
		Shutdown	OFF

\*1: 1 time flashing, interval 1.5 seconds; 2: 2 times flashing, interval 0.2 seconds.

## 2.8 Functional Description

The functions of the inverter can be summarized as follows:

### **Inverter function:**

- The inverter converts DC power into AC power that meets the requirements of the grid and feeds it into the grid.

### **Data storage function:**

- The inverter stores operating information, fault records, and other system information.

### **Parameter configuration:**

- The inverter provides a variety of parameter configurations, which can be configured via cell phone APP to meet various requirements or to optimize its operation.
- The user can configure the parameters through the mobile phone APP to meet various needs or adjust its operation to the best performance.

### **Communication interface:**

- The inverter provides communication accessory port for accessing the communication module and uploading the monitoring data to the monitoring background through wireless communication.
- After successful establishment with the communication equipment, users can view inverter-related information or set inverter operating parameters, protection parameters, etc. through the HYXiPOWER Smart Energy Management Platform.

### **Protection functions:**

- The inverter is equipped with protection functions such as islanding protection, DC reverse connection protection, AC short circuit protection, leakage current protection, surge protection, etc.

# 3 Inspection and Storage

## 3.1 Unpacking and Inspection

- The equipment has been completely tested and strictly inspected before leaving the factory, but it may still be damaged during transportation, please make a detailed inspection before signing the product.
- Check whether there is any damage to the packing box.
- Check if the goods are complete and in accordance with the packing list.
- Unpack and check if the equipment inside is intact.
- If there is any damage or incomplete goods, please contact with the shipping company or directly with Zhejiang Hyxi Technology Co., Ltd.
- Provide photos of the damage to facilitate the provision of services.

### Packing List

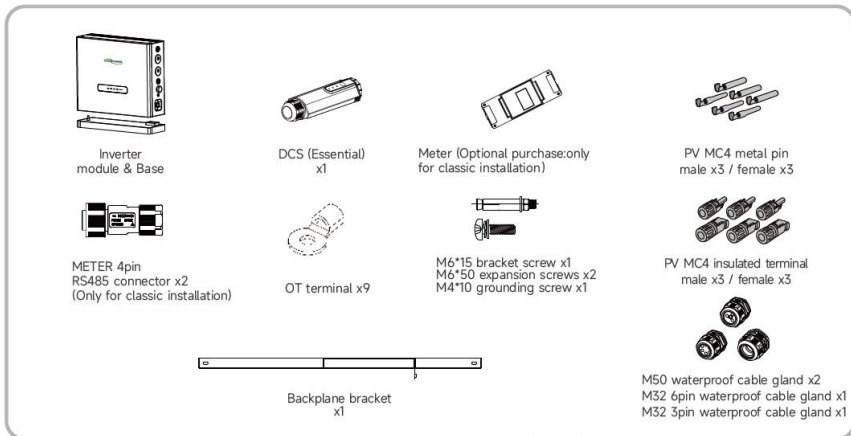

**NOTES**

Inverter Module and Base in the same package



## 3.2 Inverter Storage

If the inverter is not immediately put into use, it is necessary to meet the following requirements when storing the inverter:

- Do not remove the outer packaging of the inverter.
- The inverter needs to be stored in a clean and dry place and protected from dust and water vapor.
- The storage temperature should be kept at  $-30^{\circ}\text{C}$  to  $+60^{\circ}\text{C}$  and the relative humidity should be kept at 0% ~ 100%RH.
- When stacking multiple inverters, it is recommended that they be placed in the same number of layers as originally shipped.
- Please place the inverters carefully to avoid personal injury or equipment damage caused by tipping the equipment.
- Avoid chemically corrosive substances, otherwise it may corrode the inverter.
- During the storage period, regular inspection is required. If insects and rodents bite the inverter or damage the packaging, the packaging material should be replaced in time.
- After long-term storage, the inverter needs to be inspected and tested by professionals before it can be put into use.
- Please do not dispose of the original packaging of the equipment. It is better to store the equipment in the original box after it is dismantled.

# 4 Mechanical Installation

## 4.1 Installation Precautions

### DANGER

- Before installing the inverter, be sure that the inverter is free of any electrical connections.
- Make sure to avoid the utility alignments in the wall before drilling holes to avoid any danger.

### CAUTION

- The instructions in the manual must be followed when handling and placing the equipment.
- Improper handling of the equipment may result in minor, serious or contusive injuries.
- The equipment heat sink must be kept uncovered to ensure adequate cooling inside the equipment.

## 4.2 Unpacking for Confirmation

The inverter has been completely tested and rigorously inspected before leaving the factory, but damage may still occur during transport. Check carefully before unpacking. Check that the product information on the order and box nameplate is consistent and that the product packaging is intact.

If any damage is detected, please contact the shipping company or contact the supplier directly and provide photos of the damage to facilitate the fastest and best service. When the inverter is stored unused, please put it in the original packing box and keep it moisture and dust proof.

### **After unpacking the inverter, please check the following items:**

- Make sure the inverter main unit is complete and undamaged.
- Make sure the box contains the quick installation guide, certificate of conformity, packing list, interface accessories and installation accessories.
- Confirm that there is no damage or shortage in the delivered contents of the box.
- Verify that the product information on the order and the inverter mainframe nameplate is consistent.

## 4.3 Pre-Installation Preparation

### 4.3.1 Installation Tools

Installation tools include, but are not limited to, the following recommended tools and, if necessary, other auxiliary tools can be used in the field.



### 4.3.2 Installation Environment

#### Installation environment requirements:

- The inverter has IP65 protection level and can be used for indoor or outdoor installation.
- The installation location should be convenient for electrical connection, operation and maintenance.
- No flammable and explosive materials should be present in the installation environment.
- It must not be installed in a location that is accessible to children.
- Temperature should meet:  $-30$  to  $+60^{\circ}\text{C}$  ; Humidity should meet:  $0 \sim 100\%$  RH.
- Avoid direct sunlight, rain and snow on the inverter, and choose a sheltered place for the installation to extend the life of the inverter.
- Make sure the inverter is ventilated and dissipated smoothly, install the inverter in a ventilated environment.
- The inverter will generate some noise during operation, so it is not recommended to install it in the living area.

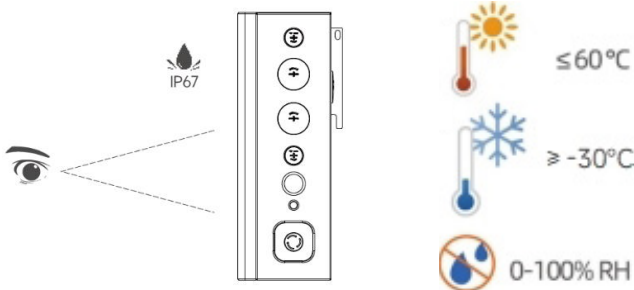

**Backplane bracket installation:**

**Step 1:** Insert the backplane bracket into the corresponding slot on the inverter module.

**Step 2:** Secure the backplane bracket to the inverter module with M6 screws.

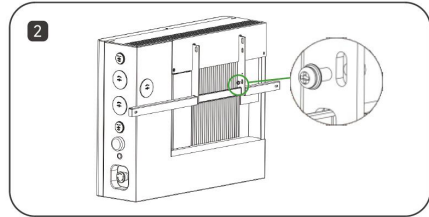
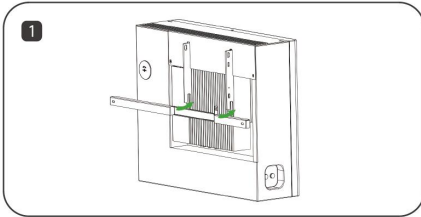
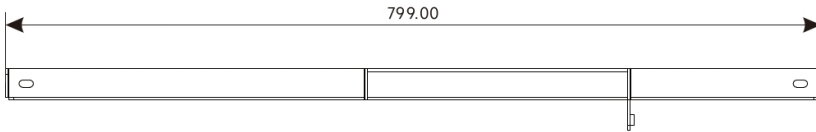

**Selecting mounting method:**

**Floor-mounted Installation**

**Step 1:** Stacking the pack on the base.

**Step 2:** Stacking the inverter module on the pack.

**Step 3:** Mark the inverter bracket's two expansion screw holes on the wall, remove the inverter module to drive expansion screws into the wall.

**Step 4:** Move back the inverter module, bolting the inverter to the wall with "M6 bracket expansion screws". (No need to fix inverter module on structural beam. The backplane bracket is only to prevent tipping, it is not a stress point.)

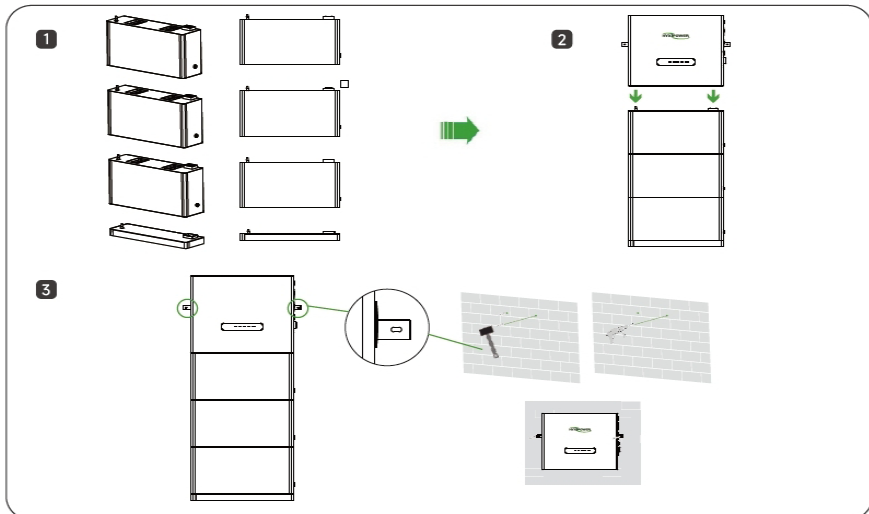

### Wall-mounted Installation (Requires purchase of additional wall-mounted base)

Wall-mounted installation for soft ground, please make sure that the wall mounted base is attached to the ground and supported by the floor, the wall mounted base is only intended for soft surfaces such as grass or mud, but still needs to be supported by the floor.

- Step 1:** Secure the wall-mounted base with "M12\*70 expansion screws". Please make sure that the expansion screws are driven into the load-bearing studs of the wall. Then place the base that comes standard in the AC battery package on the wall-mounted base.
- Step 2:** Stacking the pack on the base. Then stacking the inverter module on the pack.
- Step 3:** Mark the inverter bracket's two expansion screw holes on the wall, remove the inverter module to drive expansion screws into the wall. Move back the inverter module, bolting the inverter to the wall with "M6 bracket expansion screws". (No need to fix inverter module on structural beam. The backplane bracket is only to prevent tipping, it is not a stress point.)

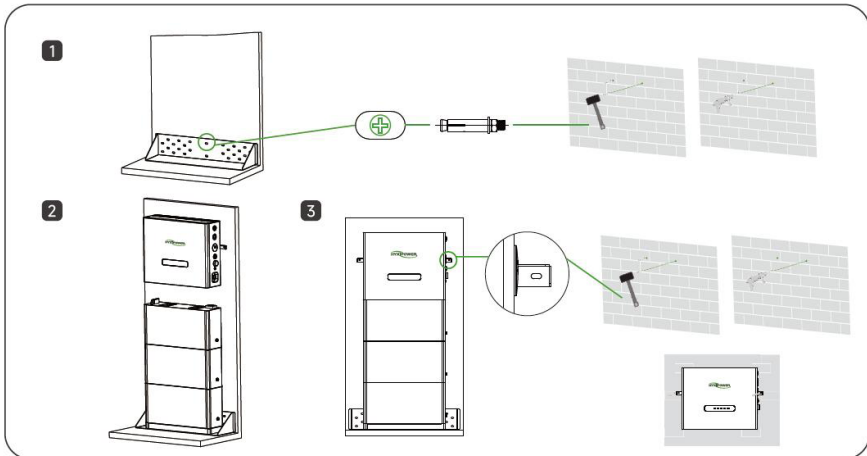

#### NOTES

The battery base (in inverter package) must be installed, otherwise the battery cannot form a circuit.

# 5 Electrical Connection

## 5.1 Electrical Connection Preparation

- Step 1:** Remove the M3\*8 screws from the top of the inverter module.
- Step 2:** Lift the inverter module cover from the upper end.
- Step 3:** Remove the 4xM6 screws from the wiring compartment cover.
- Step 4:** Unscrew the top 3 protective casing.
- Step 5:** Screw the waterproof cable gland to the corresponding position.

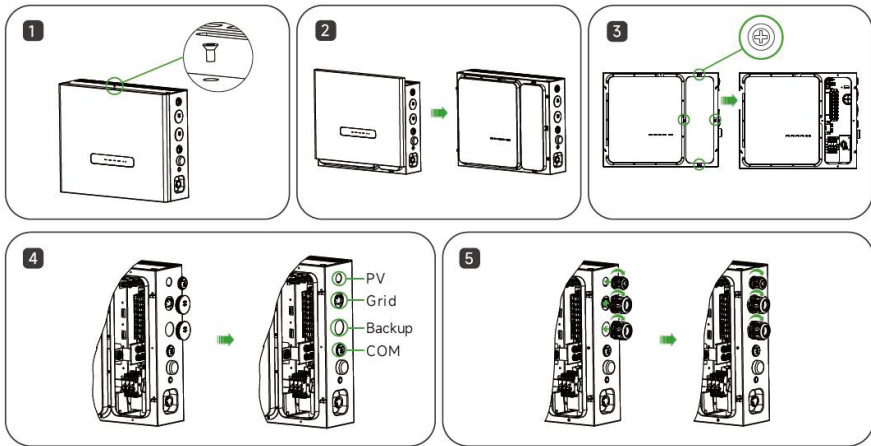

## 5.2 Grounding Connection

- Step 1:** Make the cable and crimp the terminal block.
- Step 2:** Remove the screws from the grounding terminal and use a screwdriver to secure the cable.
- Step 3:** Apply silicone or paint to the grounding terminal to improve its corrosion resistance. Secure the grounding cable to the corresponding terminals with "M4\*10 grounding screw".
- Step 4:** Thread the grounding cable through the corresponding position.

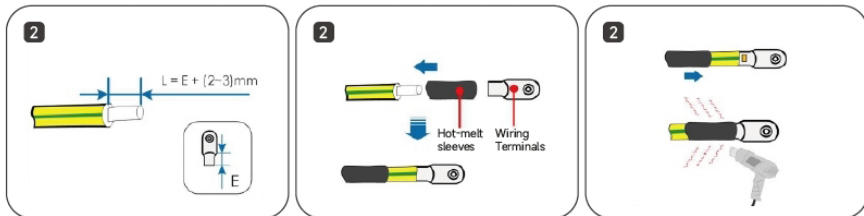

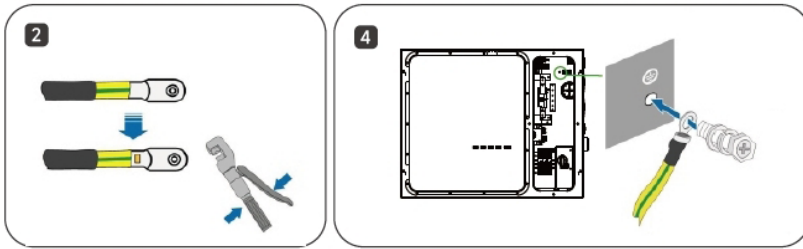

### 5.3 PV Side Connection

- Step 1:** Strip off the insulation layer of all DC cables by about 7mm.
- Step 2:** Use crimping pliers to bundle the cable ends at the wiring terminals.
- Step 3:** Pass the cable through the cable gland, insert the insulating sleeve and fasten it. Gently pull the cable to ensure that it is connected and fastened. Use a force of 2.5-3N·m to tighten the gland and insulating sleeve.
- Step 4:** Use a multi-meter to check and confirm that the polarity of the photovoltaic string connecting cable is correct.
- Step 5:** Connect the PV connectors to the corresponding terminals until a click is heard.

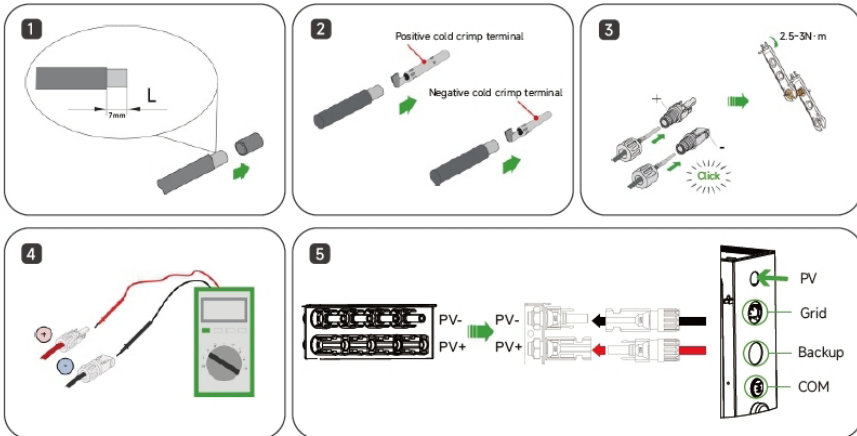

**NOTES**

PV2 and PV3 share one MPPT

## 5.4 Selecting New Installation or Classic Installation

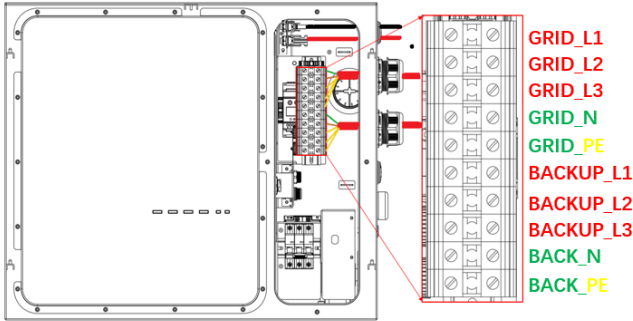

Terminal layout

### 5.4.1 New Installation

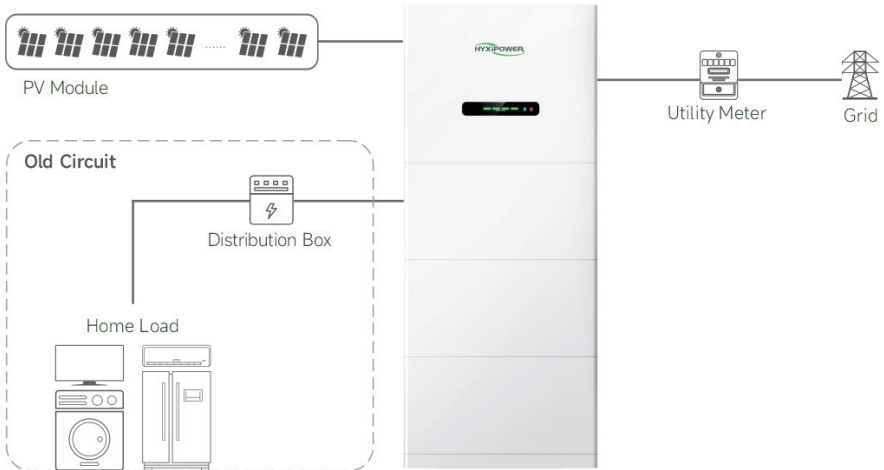

System	HYX-H6K-HTA (2BAT)	HYX-H9K-HTA (3BAT)	HYX-H12K-HTA (4BAT)	HYX-H15K-HTA (5BAT)
PV cable (copper)			4-6mm <sup>2</sup>	
AC cable (copper)			16mm <sup>2</sup>	
Backup cable (copper)			16mm <sup>2</sup>	
BAT cable (copper)			4-6mm <sup>2</sup>	
Micro-Breaker			80A	

- Step 1:** After disconnecting the power supply, take the GRID cable from GRID service entrance (AFTER utility meter), through the conduit entry port of GRID.
- Step 2:** Strip the five-core AC cable (L1/L2/L3/N/PE), and use hydraulic crimping tool to crimp each copper core together with a crimp terminal (25mm<sup>2</sup>), then connect them to the terminal chamber.
- Step 3:** Strip the five-core BACKUP cable (L1/L2/L3/N/PE), and use hydraulic crimping tool to crimp each copper core together with a crimp terminal (25mm<sup>2</sup>), then connect them to the

terminal chamber.

**Step 4:** Take the BACKUP cable through the conduit entry port of BACKUP. Connect the BACKUP cable to the main distribution box.

### 5.4.2 Classic Installation

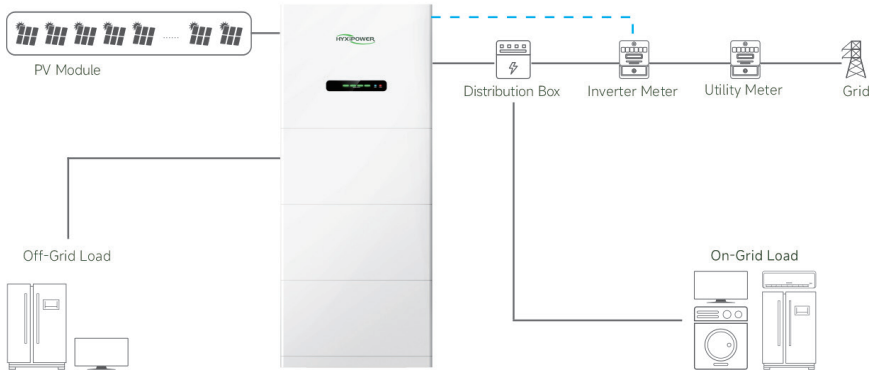

System	HYX-H6K-HTA (2BAT)	HYX-H9K-HTA (3BAT)	HYX-H12K-HTA (4BAT)	HYX-H15K-HTA (5BAT)
PV cable (copper)	4-6mm <sup>2</sup>			
AC cable (copper)	4-6mm <sup>2</sup>		6-8mm <sup>2</sup>	
Backup cable (copper)	4-6mm <sup>2</sup>		6-8mm <sup>2</sup>	
BAT cable (copper)	4-6mm <sup>2</sup>			
Micro-Breaker	30A	40A	50A	50A

- Step 1:** After disconnecting the power supply, take the GRID cable from main distribution box, through the conduit entry hole of GRID.
- Step 2:** Strip the five-core AC cable (L1/L2/L3/N/PE), and use hydraulic crimping tool to crimp each copper core together with a crimp terminal (25mm<sup>2</sup>), then connect them to the terminal chamber.
- Step 3:** Strip the five-core BACKUP cable (L1/L2/L3/N/PE), and use hydraulic crimping tool to crimp each copper core together with a crimp terminal (25mm<sup>2</sup>), then connect them to the terminal chamber.
- Step 4:** Take the BACKUP cable through the conduit entry hole of BACKUP. Connect the BACKUP cable to the sub distribution box of off-grid load.

## 5.5 Selecting WIFI Module or 4G Module

### WIFI module

**Step 1:** Insert DCS into the DONGLE terminal and tighten it to ensure it is secure.

**Step 2:** Connecting the tail end of the DCS to the head of the antenna.

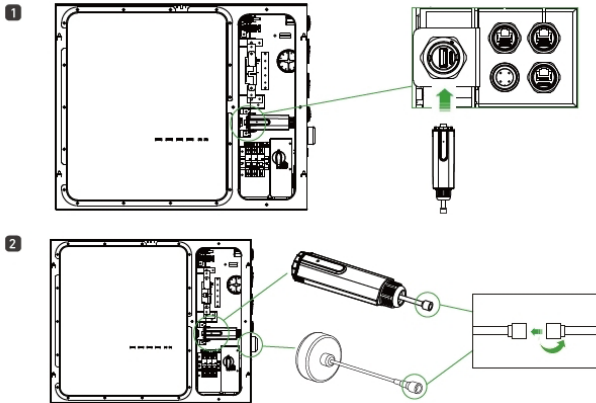

### 4G module

**Step 1:** Remove the protective cover of DCS and insert the SIM card.

**Step 2:** Install the waterproof cover of DCS.

**Step 3:** Insert DCS into the DONGLE terminal and tighten it to ensure it is secure.

**Step 4:** Connecting the tail end of the DCS to the head of the antenna.

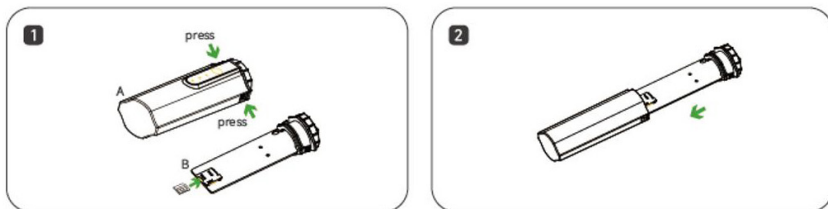

\* Step 3 and step 4 are the same as the DCS wifi module.

After completing all wiring connection, turn the battery switch on. Cover all covers. Long press the power button more than 3s until hear "click". System startup.

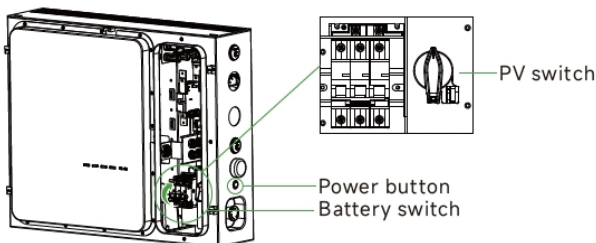

# 6 Human-Computer Interaction

## 6.1 Installing the App

### Method 1

Download and install the App through the following application stores:

- App Store (iOS)
- Google Play

### Method 2

Scan the following QR code to download and install the App according to the prompt information:



## 6.2 APP User Manual

For more information on using the HYXiPower APP, please refer to the user manual "HYXiPower APP".



## 6.3 System Debugging

For system configuration and debugging, please refer to the user manual "HYXipower Local Debugging APP".



# 7 Operation

## 7.1 Pre-Operation Inspection

Before running the PV grid-connected inverter, the following items (not limited to) must be strictly checked:

- Confirm that the installation location of the inverter meets the requirements of "4.3.2 Installation Environment" and ensure easy installation, disassembly, operation and maintenance of the inverter.
- Verify that the mechanical installation of the inverter meets the requirements of "4.3.2 Installation Environment".
- Verify that the electrical connections to the inverter meet the requirements of "5.3 PV Side Connection".
- Verify that all switches are in the "OFF" position.
- Make sure no construction tools, etc. are left on the top of the machine or in the junction box (if the machine has one).
- AC circuit breakers are selected in accordance with this manual and local standards.
- All safety signs and warning labels are securely attached and clearly visible.
- Verify that the PV module open circuit voltage meets the requirements of the DC side parameters of the inverter in the Appendix.

## 7.2 System Startup

### Normal start-up

- Long press the power button for 5 seconds until the relay engagement click is audible.

### First Start-up

(Only required when first set up or battery expansion).

After completing all wiring connection:

#### DANGER

- The following operations should be carried out when the system is completely powered off.

- Turn on the battery switch, wait for 5 seconds and turn off the battery switch, turn the battery switch on again. (For system authentication)
- Long press the power button for 5 seconds until the relay engagement click is audible.
- Turn on the PV switch.
- Turn on the breaker at the front end of the all-in-one to connect all-in-one to GRID.

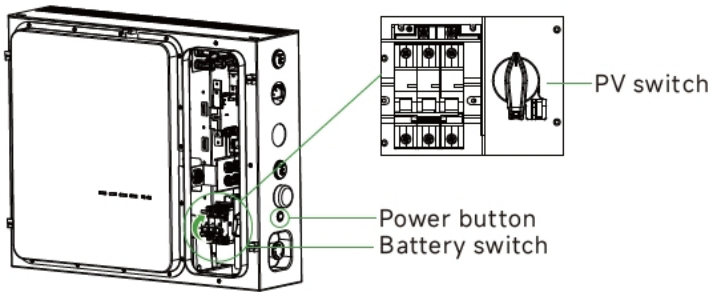

### ⚠ CAUTION

- To ensure the safe, normal and stable operation of PV power generation systems, all newly installed, renovated and repaired grid-connected PV generation system and its grid-connected inverter must be inspected before operation.

## 7.3 Grid-Connected Inverter Operation

Please strictly follow the following steps to turn on the inverter and complete the grid-connected operation of the inverter:

- Step 1:** Make sure that all items checked in "7.1 Pre-Operation Inspection" are satisfied.
- Step 2:** Close the AC side circuit breaker of the inverter public grid and the DC switch integrated with the inverter.
- Step 3:** Observe the status of the inverter LEDs (see "2.7.1 LED Indicator Status Description" for details).

## 7.4 Inverter Shutdown

### ⚠ CAUTION

- Burning hazard !
- After the inverter has been shut down, there is still a risk of burns. After the inverter has cooled down, it is necessary to wear protective gloves before operating the inverter.

It is not necessary to shut down the inverter under normal circumstances, but it is necessary to shut down the inverter when maintenance or repair work needs to be performed.

Follow the steps below to disconnect the inverter from the AC and DC power sources, as failure to do so may result in injury or damage to the equipment.

- Step 1:** Disconnect the external AC circuit breaker and prevent reconnection due to misuse.
- Step 2:** Disconnect the external DC circuit breaker and turn the DC switch of the inverter to "OFF".
- Step 3:** Wait for at least 5 minutes until the internal capacitor is completely discharged.
- Step 4:** Use a current clamp to check the DC cable to make sure there is no current.

## 7.5 Inverter Removal

### ⚠ CAUTION

- Danger of burns and electric shocks !
- After disconnecting the inverter from the grid and the PV panels, wait at least 5 minutes before touching the internal conductive components.

### ℹ NOTICE

- Before dismantling the inverter, both AC and DC must be powered down.
- If the inverter has more than two DC terminals, the outer DC connector needs to be removed before the inner DC connector can be removed.

- Step 1:** Refer to "[5 Electrical Connection](#)" and follow the steps in order to disconnect all electrical connections from the inverter. To remove the DC connector, use the MC4 wrench to loosen the locking part of the DC connector and install the waterproof plug.
- Step 2:** Refer to "[4 Mechanical Installation](#)" and follow the steps in reverse order to remove the inverter.
- Step 3:** If necessary, remove the wall plate.
- Step 4:** If the inverter is to be put into use at a later date, store the inverter properly as described in "[3.2 Inverter Storage](#)".

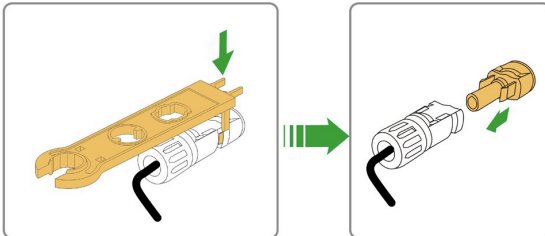

## 7.6 Ripple control

In Germany, utility uses the Ripple Control Receiver to convert the grid dispatching signal and send it as a dry contact signal.

Wiring of the ripple control receiver dry contact cables is shown in the figure below:

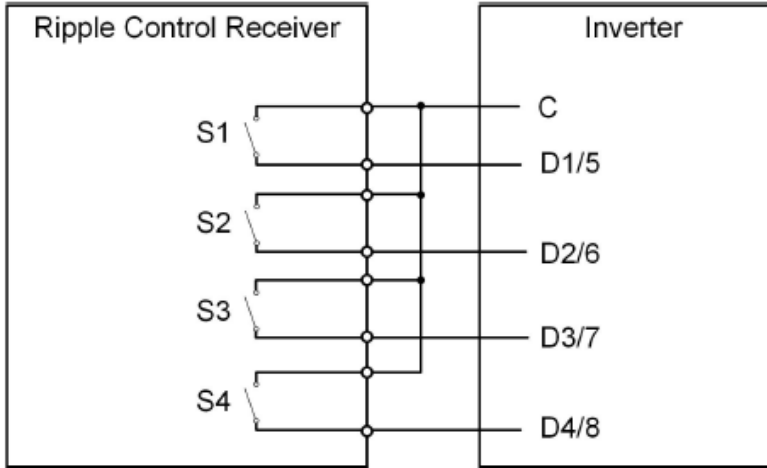

S1	S2	S3	S4	Switch operation on external RCR	Output power (in% of the rated AC output power)
0	0	0	0	None	100% (configurable according to need)
1	0	0	0	Close S1	100%
0	1	0	0	Close S2	60%
0	0	1	0	Close S3	30%
1	1	0	0	Close S1%S3	0% (disconnect from grid)

## 7.7 Disposal of Inverter

### ⚠ CAUTION

- Some parts and equipment of the inverter, such as capacitors, may cause environmental pollution.
- Please do not dispose of this product with household waste, and dispose of it in accordance with the regulations for disposal of electronic waste used at the installation site.

## 7.8 Routine Maintenance and Overhaul

In the solar PV grid-connected power generation system, the PV grid-connected inverter can automatically complete the operation of grid-connected power generation, stopping and switching on, etc. even when the day and night change and the season change.

In the solar photovoltaic grid-connected power generation system, the inverter can automatically complete the operation of grid-connected power generation and stop-start without human control. In order to ensure and extend the service life of the inverter, in addition to using the inverter in strict accordance with the contents of this manual, it is necessary to perform the necessary routine maintenance and repair of the inverter.

### 7.8.1 Maintenance Precautions

Improper maintenance operations can cause injury to personnel or damage to equipment.

#### DANGER

- Disconnect the grid-side AC circuit breaker, then disconnect the DC switch.
- Wait at least 5 minutes until the internal components are discharged before performing maintenance or service operations.
- Use test equipment to verify that no voltages or currents are present.

#### CAUTION

- When performing electrical connections and maintenance, post warning signs to prevent non-personnel from entering the electrical connection or maintenance area.
- Restart the inverter only after troubleshooting faults that affect the safety performance of the inverter.
- The inverter does not contain service parts inside, do not replace the internal components of the inverter without permission.

#### CAUTION

- Please contact HYXiPOWER after-sales service for maintenance, unauthorized disassembly of the machine Hyxipower will not assume any warranty and joint and several responsibilities.
- Comply with electrostatic protection norms and wear anti-static bracelets to avoid unnecessary contact with the circuit board.

## 7.8.2 Routine Maintenance

Inspection content	Inspection method	Maintenance interval
Save inverter operation data	<ul style="list-style-type: none"> <li>Use monitoring software to read the inverter data in real time and regularly backup the data recorded by the monitoring software.</li> <li>Save the operation data, parameters, and logs of the inverter recorded in the monitoring software to a file.</li> <li>Check the monitoring software and view various parameter settings of the inverter through the hand-held keyboard.</li> </ul>	Every 6 months
Inverter operation condition	<ul style="list-style-type: none"> <li>Observe whether the inverter is firmly installed, and whether there is damage or deformation. Listen to the inverter for abnormal sounds.</li> <li>When the system is connected to the grid, check various variables. Check whether the inverter housing is heating normally, and use a thermal imager to monitor the system heating.</li> </ul>	Every 6 months
Inverter cleaning	<ul style="list-style-type: none"> <li>Check the humidity and dust in the environment around the inverter, and clean the inverter if necessary.</li> </ul>	Every 6 months
Electrical connection	<ul style="list-style-type: none"> <li>Check whether the system cable connection is loose and the inverter wiring terminals are loose, and then tighten them according to the method specified in Section 5.5.2.</li> <li>Check the cable for damage, especially if there are cuts on the skin that contact the metal surface.</li> </ul>	Every 6 months
Safety functions	<ul style="list-style-type: none"> <li>Check the inverter LEDs and system shutdown function.</li> <li>Simulate the shutdown and check the shutdown signal communication.</li> <li>Check the warning label and replace it if necessary.</li> </ul>	Every 6 months

## 7.9 Function Settings Explanation

### 7.9.1 Work Mode

HYXiPOWER inverter can meet different scenarios based on different needs. There are totally 4 on-grid working mode (Depending on the needs of different usage scenarios, you can customise the effective period of these four working modes) and 1 off-grid working mode (Automatic switching from on-grid to off-grid mode in case of blackout).

Working modes	Description
Selfuse	Make energy self-circulating to achieve the purpose of buying as little electricity as possible from grid.
Backup	Do not to use battery to ensure always have enough backup. Not allowed to buy electricity from grid to charge battery.
Forced charge	Do not to use battery to ensure always have enough backup. Forced to buy electricity from grid to charge battery at the settled power.
Feedin	Feedin energy to grid at maximum power until battery reaches min SOC.

Please see more details in *APP User Manual -- 3.2.5 Device Operations*.



### 7.9.2 Export Control

This function determines the upper limit of the power allowed to feedin to GRID.

- If disabled, there will be no restriction on the power fed into the grid(PV energy will not feedin grid but only supply loads or battery).
- If abled, users can set the upper limit of the power allowed for feedin to GRID.

e.g. set to 0, feed-in to GRID is completely disallowed(0 injection).

e.g. set to 1000W, the maximum power for feedin will not exceed 1000W (rather than forcing it to be exactly 1000W for feedin).

### 7.9.3 Retrofit

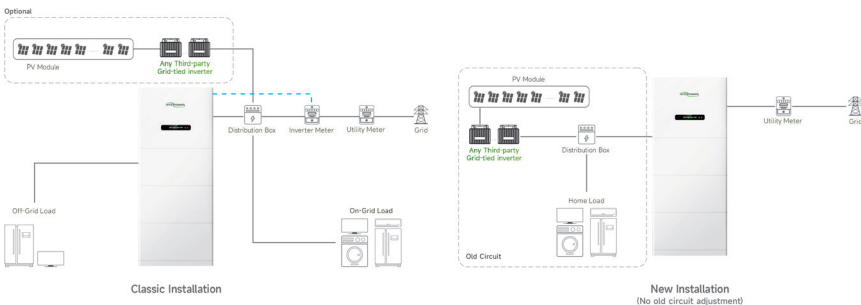

All-in-one can be integrated with any third-party PV to form a system. When matching with a thirdparty inverter, the following prerequisites must be met:

Installation method	0 injection	Third-party PV size	Frequency-Dependent Power Reduction(FDPR) ①	Conclusion
New	Require	≤ All-in-one backup continuous output power	Third-party inverter <b>support</b> FDPR	Y ②
			Third-party inverter <b>NOT</b> support FDPR	N
		> all-in-one backup continuous output power	Third-party inverter <b>support</b> FDPR	
			Third-party inverter <b>NOT</b> support FDPR	
	No need	≤ all-in-one backup continuous output power	Third-party inverter <b>support</b> FDPR	
			Third-party inverter <b>NOT</b> support FDPR	
		> all-in-one backup continuous output power	Third-party inverter <b>support</b> FDPR	
			Third-party inverter <b>NOT</b> support FDPR	
Classic	Require	≤ all-in-one backup continuous output power	Third-party inverter <b>support</b> FDPR	N
			Third-party inverter <b>NOT</b> support FDPR	
		> all-in-one backup continuous output power	Third-party inverter <b>support</b> FDPR	
			Third-party inverter <b>NOT</b> support FDPR	
	No need	≤ all-in-one backup continuous output power	Third-party inverter <b>support</b> FDPR	Y
			Third-party inverter <b>NOT</b> support FDPR	
		> all-in-one backup continuous output power	Third-party inverter <b>support</b> FDPR	
			Third-party inverter <b>NOT</b> support FDPR	

① FDPR: This functional requirement exists in IEC (International Electrotechnical Commission) standards such as IEC 61850 and IEC 60909, and inverters with safety certificates generally support FDPR.

② To prevent feedin from third-party PV systems, all-in-one will charge the battery with the energy fed by the third-party PV. When the battery is nearly fully charged, to avoid penalties from the grid due to unauthorized feed-in by the third-party PV, all-in-one has to switch to off-grid operation.

# 8 Appendix

## 8.1 Technical Parameter

Battery System	HYX-H6K-HTA	HYX-H9K-HTA	HYX-H12K-HTA	HYX-H15K-HTA
<b>System</b>				
Hybrid Inverter			1	
Battery Module	2	3	4	5
Base			1	
<b>PV Data</b>				
Max. Input Power (max input power of each string)	160% Rated Total 9,600W (each string ≤ 8,000W)	160% Rated Total 14,400W (each string ≤ 8,000W)	160% Rated Total 19,200W (each string ≤ 8,000W)	160% Rated Total 24,000W (each string ≤ 8,000W)
Max. Input Voltage	1,000V			
MPPT Operating Voltage Range	140 - 980V			
Start-Up Voltage	160V			
Max. Input Current	20A / 40A			
Max. Short Circuit Current	30A / 60A			
Number of MPPT	2			
PV Input Number (Number of String Per MPPT)	3 (1 / 2)			
<b>AC Data</b>				
Grid Type	3/N/PE, 220V/380V, 230V/400V, 240V/415V			
Nominal Frequency	50Hz / 60Hz			
Max. Passthrough Current	63A per phase			
Max. Apparent Power	6,600VA	9,900VA	13,200VA	16,500VA
Output to Utility				
Output Power Factor	0.8 leading ... 0.8 lagging			
THDi	<3%			
<b>Backup</b>				
Max. Continuous Output Power	6,600W	9,900W	13,200W	16,500W
Peak Output Power (with PV)	150% Rated 9,000W, 10s	150% Rated 13,500W, 10s	150% Rated 18,000W, 10s	150% Rated 22,500W, 10s
Switch Time	< 10ms			
<b>Battery</b>				
Battery Type	LiFePO4			
Total Battery Capacity	10.6kWh	15.9kWh	21.2kWh	26.5kWh
<b>General</b>				
Operating Temperature	-10 to +50 °C			
Cooling Method	Natural Cooling			
Ingress Protection	IP67			
Dimensions (W*H*D)	700*1320*200mm	700*1670*200mm	700*2020*200mm	700*2370*200mm
Weight	TOP module (46.4kg)*1+PACK (44kg)*N+base (5.6kg)*1			
Max. Operating Altitude	4,000m			
User Interface	LED / App / Web			
Communication	CAN / RS485 / WIFI / 4G / LAN / PLC			

## 8.2 Alarm Code

Fault code	Fault description	Solution
7232	Grid overvoltage/high voltage level 1	<p>After the grid returns to normal, inverter will re-connected to it generally.</p> <ul style="list-style-type: none"> <li>• Measure the actual grid voltage, if the grid voltage is truly higher than the set value, please contact the utility.</li> <li>• Check the protection parameter setting of the upper computer and confirm that it meets the requirements.</li> <li>• Confirmation of non-above reasons, and the fault still exists, please contact HYXiPOWER customer service.</li> </ul>
7233	Grid overvoltage/high voltage level 2	Same as high voltage level 1.
7234	Grid overvoltage/high voltage level 3	Same as high voltage level 1.
7235	Grid transient overvoltage	<p>After the grid returns to on-grid status, inverter will be re-connected to it generally. If the fault occurs repeatedly, please contact HYXiPOWER customer service.</p>
7242	Grid underfrequency/low frequency level 1	<ul style="list-style-type: none"> <li>• Check whether the protection parameter settings meet the requirements through APP or LCD screen.</li> <li>• Confirmation of non-above reasons, and the fault still exists, please contact HYXiPOWER.</li> </ul>
7299	Boost4_PV Reverse Fault	Same as Boost1_PV Reverse Fault
7300	Boost5_PV Reverse Fault	
7301	Boost6_PV Reverse Fault	
7302	Boost7_PV Reverse Fault	
7303	Boost8_PV Reverse Fault	
7304	Boost9_PV Reverse Fault	
7305	Boost10_PV Reverse Fault	
7306	Boost11_PV Reverse Fault	
7307	Boost12_PV Reverse Fault	
7327	Boost1_PV overvoltage	<ul style="list-style-type: none"> <li>• Check whether the PV input voltage exceeds the rated input voltage, if so, adjust the PV input voltage to restart within the normal operating range of the inverter.</li> <li>• Confirmation of non-above reasons, and the fault still exists, please contact HYXiPOWER customer service.</li> </ul>

7329	Boost2_PV overvoltage	Same as Boost1_PV overvoltage
7331	Boost3_PV overvoltage	
7333	Boost4_PV overvoltage	
7335	Boost5_PV overvoltage	
7337	Boost6_PV overvoltage	
7339	Boost7_PV overvoltage	
7341	Boost8_PV overvoltage	
7343	Boost9_PV overvoltage	
7345	Boost10_PV overvoltage	
7347	Boost11_PV overvoltage	
7349	Boost12_PV overvoltage	
7626	Boost1_PV Overload Fault	
7627	Boost2_PV Overload Fault	Same as Boost1_PV Overload Fault
6848	High ambient temperature	<p>After the internal temperature or module temperature returns to normal, inverter will be re-connected to the network generally. If the fault occurs repeatedly:</p> <ul style="list-style-type: none"> <li>Check whether the ambient temperature of inverter is too high.</li> <li>Check whether inverter is in an easily ventilated place.</li> <li>Check whether inverter is in direct light, if so, please shade properly.</li> <li>Check whether the fan is running normally, if not , please replace the fan.</li> <li>Confirmation of non-above reasons, and the fault still exists, please contact Hyxipower customer service.</li> </ul>
6849	Low ambient temperature	Shut down and disconnect the inverter. Waiting for the ambient temperature to rise to within the inverter operating temperature range , then restart the inverter.

7365	Leakage current exceeds the standard	<ul style="list-style-type: none"> <li>Humid environment of the battery panel or bad light will cause this fault, normally, the inverter will be re-connected to the grid after the environment is improved.</li> <li>If the environment is normal, check whether the insulation of DC and AC cables is normal.</li> <li>Confirmation of non-above reasons, and the fault still exists, please contact Hyxipower customer service.</li> </ul>
7366	Low system insulation impedance	<p>Wait for the inverter to return to normal, if the fault occurs repeatedly:</p> <ul style="list-style-type: none"> <li>Check whether the ISO impedance protection value is too high through APP, and confirm that it meets the requirements of local regulations.</li> <li>Check the strings and the DC cable impedance to ground, if there is a short-circuit or the cable insulation layer is broken, please take corrective measures.</li> <li>If the cables are normal and the fault occurs on a rainy day, reconfirm after the weather improves;</li> <li>Confirmation of non-above reasons, and the fault still exists, please contact HYXiPOWER customer service.</li> </ul>
7367	Ground Fault	<ul style="list-style-type: none"> <li>Check whether the AC cable is connected to the wrong wire sequence.</li> <li>Check whether the insulation between ground and fire wire is normal.</li> <li>Confirmation of non-above reasons, and the fault still exists, please contact HYXiPOWER.</li> </ul>
7386	Boost7_PV Hardware Overcurrent Fault	<p>If the fault occurs repeatedly, please contact HYXiPOWER customer service.</p>
7387	Boost8_PV Hardware Overcurrent Fault	
7388	Boost9_PV Hardware Overcurrent Fault	
7389	Boost10_PV Hardware Overcurrent Fault	
7390	Boost11_PV Hardware Overcurrent Fault	
7391	Boost12_PV Hardware Overcurrent Fault	
7392	Inverter Self-Test Fault	<p>Power down and restart or clear the fault from the self-test menu, if the fault still exists in the self-test startup again, please contact HYXiPOWER customer service!</p>

7488	Main and auxiliary DSP communication abnormality	<ul style="list-style-type: none"> <li>Try to power down and restart the inverter.</li> <li>Confirmation of non-above reason, and the fault still exists, please contact HYXiPOWER customer service.</li> </ul>
7489	DSP2 communication abnormality	Same as 7488
7491	Fan Warning	<ul style="list-style-type: none"> <li>Try inverter power down and restart.</li> <li>Check if the fan wiring is loose or damaged and whether the fan blades are blocked.</li> <li>Confirmation of non-above reason, and the fault still exists, please contact HYXiPOWER customer service.</li> </ul>
7492	Inverter Over-temperature Warning	Same as Inv radiator over-temperature
7493	Boost Over-temperature Warning	Same as Boost radiator over-temperature
7494	DSP Over-temperature Warning	Same as high temperature
7495	Inverter Undertemperature Warning	Shut down and disconnect the inverter. Wait for the INV side temperature to rise to within the inverter operating temperature range, then restart the inverter.
7496	Boost Under-temperature Warning	Shut down and disconnect the inverter. Wait for the PV side temperature to rise to within the inverter operating temperature range, then restart the inverter.
7497	DSP Under-temperature Warning	Shut down and disconnect the inverter. Wait for the environment temperature to rise to within the inverter operating temperature range, then restart the inverter.
7498	ARM communication Abnormalty	<ul style="list-style-type: none"> <li>Try to power down and restart the inverter.</li> <li>Confirmation of non-above reason, and the fault still exists, please contact HYXiPOWER customer service.</li> </ul>
7502	Temperature Warning	Same as high/low temperature warning
7504	Negative grid sequence	Please contact HYXiPOWER customer service.
7505	DC lightning protection	
7506	AC lightning protection	
7427	Bat1 Battery Hardware Overvoltage Fault	If the fault occurs repeatedly, please contact HYXiPOWER customer service.
7428	Bat1 Battery Hardware Overcurrent Fault	
7552	Meter communication	Please contact HYXiPOWER customer service.
7553	Battery communication	
7554	Overload Fault	
7555	Product type error	

7556	AFCI communication fault	Please contact HYXiPOWER customer service.
7557	Power level mismatch	
7558	AFCI arc fault	
7559	Insufficient off-grid energy supply	
7560	Battery sleep	
7561	Battery Emergency Stop Fault	
7562	Optimizer communication Fault	

### 8.3 Quality Assurance

Zhejiang Hyxi Technology Co., Ltd. (hereinafter referred to as the Company) will repair or replace the product with a new one free of charge.

#### Evidence:

During the warranty period, customers need to show the invoice and date of purchase of the product. At the same time, the trademark on the product should be clearly visible, or the right not to quality assurance.

#### Conditions:

The replacement defective products shall be disposed of by the Company; the customer shall allow reasonable time for the Company to repair the defective equipment.

#### Liability Exemption:

We have the right not to carry out quality assurance if the following circumstances occur.

- The whole machine and parts have exceeded the free warranty period.
- Shipping damage.
- Incorrect installation, modification or use.
- Operation in very harsh environments beyond those described in this manual.
- Machine failure or damage caused by installation, repair, alteration or disassembly not by our service organization or personnel.
- Installation and use beyond the scope specified in the relevant international standards.
- Damage caused by an abnormal natural environment.

#### NOTICE

- In case of changes in product dimensions and parameters, the latest information of our company shall prevail without prior notice.

## 8.4 Contact Information

If you have any questions about this product, please contact us.

In order to provide you with faster and better after-sales service, we need your assistance in providing the following information.

- Equipment model : \_\_\_\_\_
- Serial number of the device: \_\_\_\_\_
- Fault code / name: \_\_\_\_\_
- A brief description of the fault phenomenon: \_\_\_\_\_  
\_\_\_\_\_  
\_\_\_\_\_  
\_\_\_\_\_

Version: UM\_HYX-H15K-HTA\_V2.0-202507\_EN

The manual is subject to change without notice while the product is being improved.



**Zhejiang Hyxi Technology Co., Ltd.**

Building 1, No. 57 Jiang'er Road, Changhe Street, Binjiang District,  
Hangzhou, Zhejiang Province, China

[www.hyxipower.com](http://www.hyxipower.com)

[support@hyxipower.com](mailto:support@hyxipower.com)