

# User Manual OF SMILE - G3 - S6 / S5 / S3.6 / B5

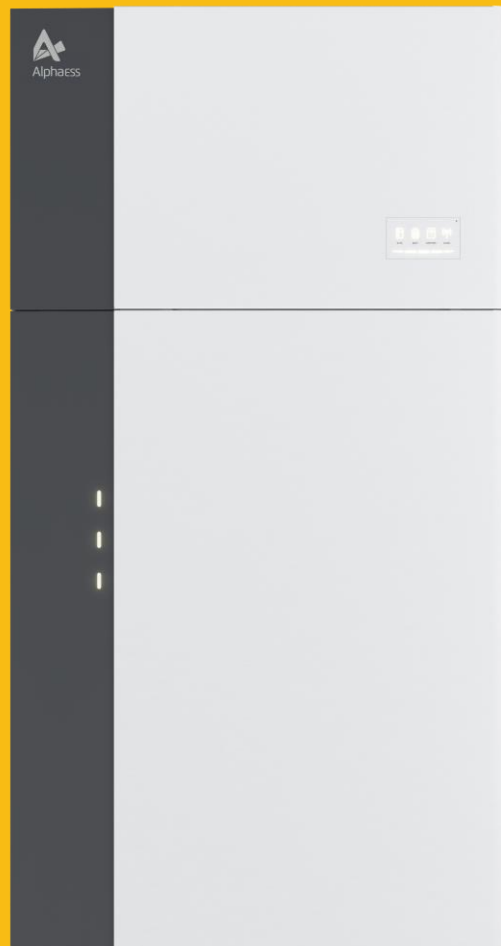



---

## **DISCLAIMER**

Copyright © AlphaESS Co., Ltd. 2022. All rights reserved.

No part of this document may be reproduced or transmitted in any form or by any means without prior written consent of Alpha ESS Co., Ltd.

The material furnished in this document is believed to be accurate and reliable. The information and recommendations in this document do not constitute commitments or warranties in the form of assignments. The information in this document is subject to change without notice. You may refer to the AlphaCloud Platform (<https://cloud.alphaess.com>) for the most updated version.

All company and brand products and service names are trademarks or registered trademarks of their respective holders.

## **COPYRIGHT STATEMENT**

This manual is under the copyright of Alpha ESS Co., Ltd. with all rights reserved. Please retain this manual and operate the Product in accordance with all safety and operating instructions in this manual. Please do not operate the product before reading through the manual.

**CONTENT**

**DISCLAIMER ..... 1**

**COPYRIGHT STATEMENT..... 2**

**CONTENT ..... 3**

**1. Introduction ..... 5**

**1.1. Content and Structure of this Document ..... 5**

**1.2. Levels of Warning Messages..... 5**

**1.3. Definition of Abbreviations and Nouns..... 6**

**2. Safety ..... 7**

**2.1. Intended Use ..... 7**

**2.2. Battery Safety Instructions ..... 8**

        2.2.1. General Safety Precautions..... 8

        2.2.2. Response to Emergency Situations ..... 8

**2.3. Important Safety Instructions ..... 9**

**2.4. Symbols Explanation ..... 13**

**3. Product Introduction and Application Scenarios ..... 16**

**3.1. Naming Convention ..... 16**

**3.2. System Introduction..... 17**

**3.3. Product Description ..... 18**

        3.3.1. Inverter Electrical Interface & Connections Introduction..... 18

        3.3.2. Inverter Display Interface Introduction..... 19

        3.3.3. Battery Display Interface Introduction..... 20

        3.3.4. Battery Introduction of SMILE-G3-BAT-10.1P ..... 21

        3.3.5. Battery Introduction of SMILE-G3-BAT-8.2P ..... 22

        3.3.6. Battery Introduction of SMILE-G3-BAT-3.6S/4.0S ..... 23

        3.3.7. Battery Introduction of SMILE-G3-BAT-3.8S ..... 24

**3.4. Application Scenarios ..... 25**

---

3.4.1. DC-Coupled Storage System .....	25
3.4.2. AC-Coupled Storage System.....	25
3.4.3. Hybrid-Coupled Storage System.....	26
3.4.4. Off-Grid Storage System .....	26
<b>4. Power on and off the System.....</b>	<b>27</b>
<b>4.1. Power on the System.....</b>	<b>27</b>
<b>4.2. Power off the System .....</b>	<b>28</b>
<b>5. Operation .....</b>	<b>29</b>
<b>5.1. Monitor System on AlphaESS APP .....</b>	<b>29</b>
5.1.1. Download and Install the App .....	29
5.1.2. Register as an End User.....	29
<b>5.2. Monitor System on AlphaCloud .....</b>	<b>30</b>
5.2.1. Register an End User Account on AlphaCloud.....	30
<b>5.3. Reconfigure Network.....</b>	<b>32</b>
<b>6. Maintenance and Troubleshooting .....</b>	<b>33</b>
<b>6.1. Routine Maintenance.....</b>	<b>33</b>
<b>7. Product Removal &amp; Return.....</b>	<b>34</b>
<b>7.1. Removing the Product.....</b>	<b>34</b>
<b>7.2. Packing the Product .....</b>	<b>34</b>
<b>7.3. Disposing of the Product .....</b>	<b>34</b>

## 1. Introduction

### 1.1. Content and Structure of this Document





This document is valid for the SMILE-G3 single phase energy storage system which includes inverter SMILE-G3-S6/S5/S3.6/B5-INV and battery SMILE-G3-BAT-8.2P/10.1P, and SMILE-G3-BAT-3.6S/3.8S/4.0S. SMILE-G3-BAT-3.6S is only for Greece market.

This document describes the general safety precautions, product information and application scenarios of the energy storage system as well as the basic operation of the user interface.

Illustrations in this document are reduced to the essential information and may deviate from the real product.

### 1.2. Levels of Warning Messages

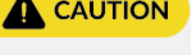
The following levels of warning messages may occur when handling the product.

	<p>DANGER indicates a hazardous situation that will result in death or serious injury if not avoided.</p>
	<p>WARNING indicates a hazardous situation that could result in death or serious injury if not avoided.</p>
	<p>CAUTION indicates a hazardous situation that could result in minor or moderate injury if not avoided.</p>
	<p>NOTICE indicates a situation that could result in property damage if not avoided.</p>
<p>INFORMATION provides tips which are valuable for the optimal installation and operation of the product.</p>	

### 1.3. Definition of Abbreviations and Nouns

#### A

AC alternating current

APP application

AUX auxiliary

#### B

BAT battery

BMS battery management system

#### D

DC direct current

#### E

EMS energy management system

#### I

INV inverter

#### P

PV photovoltaic

## 2. Safety

### 2.1. Intended Use

The inverter, batteries and electricity meters together form a system designed to optimise the self-consumption of electrical energy in a household. The inverter transfers energy between AC current and DC current while the battery is used for the storage of energy (typically storing surplus energy produced by solar arrays).

SMILE-G3-S6/S5/S3.6/B5-INV, SMILE-G3-BAT-10.1P and SMILE-G3-BAT-3.6S/4.0S are suitable for indoor and outdoor installation.

SMILE-G3-BAT-8.2P and SMILE-G3-BAT-3.8S are only suitable for indoor installation.

The SMILE-G3-S6/S5/S3.6-INV must only be operated with PV arrays of protection class II in accordance with IEC 61730, application class A. The PV modules must be compatible with this product.

The product is not equipped with an integrated transformer and therefore has no galvanic isolation.

The product must not be operated with PV modules whose outputs are grounded. This can cause the product to be destroyed. The product may be operated with PV modules whose frame is grounded.

PV modules with a high capacity to ground must only be used if their coupling capacity does not exceed 1.0  $\mu\text{F}$ .

All components must be used in a manner and environment in compliance with the requirements of this manual and in compliance with all relevant local Standards and directives. Any other operation may cause personal injury or property damage.

Alterations to the product, e.g. changes or modifications, are only permitted with the express written permission of AlphaESS. Unauthorized alterations will void the product warranty(s). AlphaESS shall not be held liable for any damage caused by such changes.

Any use of the product other than that described in the Intended Use section does not qualify as appropriate.

The enclosed documentation is an integral part of this product. Keep the documentation in a convenient place for future reference and comply with all instructions contained therein.

The type label must remain permanently attached to the product.

## 2.2. Battery Safety Instructions

### 2.2.1. General Safety Precautions

- Overvoltage or incorrect wiring can damage the battery and cause deflagration, which can be extremely dangerous.
- All types of battery breakdown may lead to electrolyte or flammable gas leakage.
- The battery is not user-serviceable because there is high voltage in the device.
- Read the label with Warning Symbols and Precautions on the right side of the battery.
- Do not connect any AC conductors or PV conductors directly to the battery which should be connected only to the inverter.
- Do not charge or discharge a damaged battery.
- Do not damage the battery by dropping, deforming, impacting, cutting or penetrating it with a sharp object. Battery damage may cause a leakage of electrolyte or fire.
- Do not expose the battery to an open flame.

### 2.2.2. Response to Emergency Situations

The battery is designed to prevent the danger caused by malfunction.

- In the case of user exposure to the electrolyte or other internal materials of the battery cells, the list below details recommended actions dependent on the type of exposure:
  1. Inhalation: Leave the contaminated area immediately and seek medical attention.
  2. Eye injuries: Rinse eyes with running water for 15 minutes and seek medical attention.
  3. Skin injuries: Wash the affected area thoroughly with soap and seek medical attention.
  4. Ingestion: Induce vomiting and seek medical attention.

If a fire breaks out in the place where the battery is installed, perform the following countermeasures:

- Fire extinguishing media
  1. Respirator is not required during normal operations.
  2. Use FM-200 or CO<sub>2</sub> extinguisher for battery fire.
  3. Use an ABC fire extinguisher if the fire is not from battery and hasn't spread to it yet.
- Firefighting instructions
  1. If fire occurs when charging the battery, disconnect the battery circuit breaker to shut off the power to charge if it is safe to do so.
  2. If the battery is not on fire yet, extinguish the fire before the battery catches fire.
  3. If the battery is on fire, do not try to extinguish it but evacuate people immediately.

**WARNING**

There may be a possible explosion when batteries are heated above 150°C. When the battery is burning, it leaks poisonous gases. Do not approach.

- Effective ways to deal with accidents
  1. On land: Place damaged battery in a segregated place and call local fire department or technical service engineer.
  2. In water: Stay out of the water and don't touch anything if any part of the battery, inverter, or wiring is submerged.
  3. Do not use submerged battery again and contact an AlphaESS-Accredited or Battery-Accredited technical service engineer.

### 2.3. Important Safety Instructions

**DANGER**

**Danger to life due to electric shock when live components or DC cables are touched.**

The DC cables connected to a battery or a PV module may be live. Touching live DC cables can result in serious injury or even death due to electric shock. To avoid this danger:

- Disconnect the inverter and battery from voltage sources and make sure it cannot be reconnected before working on the device.
- Do not touch non-insulated parts or cables.
- Do not disconnect the DC connectors under load.
- Wear suitable personal protective equipment for all work on the product.
- Observe all safety information of this document.

**DANGER**

**Danger to life due to electric shock if live system components in backup mode are touched**

Even if the grid circuit breaker and the PV switch of the inverter are disconnected, parts of the system may still be live when the battery is switched on due to backup mode. To avoid this danger:

- Before performing any work on the inverter, disconnect it from all voltage sources as described in this document.

 **DANGER****Danger to life due to electric shock if touching live components or DC cables when working on the battery**

The DC cables connected to the battery may be live. Touching live DC cables can result in serious injury or even death due to electric shock. To avoid this danger:

- Before performing any work on the battery, disconnect the inverter from all voltage sources as described in this document.

 **DANGER****Danger to life due to electric shock if touching live components when the inverter or battery cover is open**

High voltages are present in the live parts and cables inside the system during operation. Touching live parts and cables can result in significant injuries or even death due to electric shock. To avoid this danger:

- Do not open the system.

 **DANGER****Danger to life due to electric shock if live components are touched during a ground fault.**

When a ground fault occurs, parts of the energy storage system may still be live. Touching live parts and cables can result in significant injuries or even death due to electric shock. To avoid this danger:

- Disconnect the product from voltage sources and make sure it cannot be reconnected before working on the device.
- Touch the cables of the PV array on the insulation only.
- Do not touch any parts of the substructure or frame of the PV array.
- Do not connect PV strings with ground faults to the inverter.

 **DANGER****Danger to life due to electric shock if an ungrounded PV module or array frame is touched.**

Touching ungrounded PV modules or array frames can result in significant injuries or even death due to electric shock. To avoid this danger:

- Connect and ground the frame of the PV modules, the array mounting frame and the electrically conductive surfaces to ensure continuous conduction.
- Observe the applicable local regulations.

**Danger to life due to dangerous voltages on the battery.**

There is dangerous voltage at the terminal of the battery power cable. Reaching into the terminal of the battery power cable can result in a lethal electric shock. To avoid this danger:

- Do not open the battery cover.
- Leave the protective caps on the connectors for the battery's power connection until the inverter cables are connected to the battery.
- Disconnect the system from voltage sources and make sure it cannot be reconnected before working on the inverter or the battery.

**Risk of chemical burns from electrolyte or toxic gases.**

During normal operation, no electrolyte would leak from the battery and no toxic gases would form. Despite careful construction, if the battery is damaged or a fault occurs, it is possible that electrolyte may leak or toxic gases may form. To avoid this danger:

- Store the battery in a cool and dry place.
- Do not drop the battery or expose it to sharp objects.
- Protect the battery from mechanical damage from vehicles, tools and other objects.
- Only set the battery down on its back or its base.
- Do not open the battery.
- Do not install or operate the battery in a potentially explosive atmosphere or areas of high humidity.
- If moisture has penetrated the battery (e.g. due to a damaged housing), do not install or operate the battery.
- In case of contact with electrolyte, rinse the affected areas immediately with water and seek medical attention without delay.

**Danger to life due to burns caused by electric arcs through short-circuit currents.**

Short-circuit currents in the battery can cause heat build-up and electric arcs. Heat build-up and electric arcs may result in lethal injuries due to burns. To avoid this danger:

- Disconnect the battery from all voltage sources before performing any work on it.
- Observe all safety information of this document.

 CAUTION**Risk of burns from the inverter's hot surface.**

The surface of the inverter can get extremely hot during operation, and touching it can result in burns. To avoid this danger:

- Correctly mount the inverter so that it cannot be inadvertently touched.
- Do not touch hot surfaces.
- Wait for 30 minutes for surfaces to cool down after switching the system off.
- Observe the safety messages on the inverter.
- During operation, don't touch any parts other than the display panel of the inverter.

 CAUTION**Risk of injury due to weight of the inverter and battery.**

Injuries may be caused if the product is lifted incorrectly or dropped while being transported or mounted. To avoid this danger:

- Transport and lift the product carefully. Take the weight of the product into account. Use lifting and conveyance aids such as lifting trolleys wherever possible.
- Wear suitable personal protective equipment for all work on the product.

 NOTICE**Damage to the inverter and battery due to electrostatic discharge.**

Touching electronic components can result in electrostatic discharge, which can damage or destroy the inverter and battery. To avoid this:

- Ground yourself before touching any component.











 NOTICE**Damage due to cleaning agents or inappropriate cleaning methods**

The use of cleaning agents may cause damage to the product and its components. To avoid this:















- Clean the product and all its components only with a cloth moistened with clear water.
- Never clean the unit with a hose or with the use of a water jet.

## 2.4. Symbols Explanation

Symbols on the type label of the energy storage inverter

Symbol	Explanation
	Beware of a danger zone This symbol indicates that the product must be additionally grounded if additional grounding or equipotential bonding is required at the installation site.
	Beware of electrical voltage The product operates at high voltages.
	Beware of hot surface The inverter can get hot during operation.
	Danger to life due to high voltages in the inverter; observe a waiting time of 5 minutes. High voltages that can cause lethal electric shocks are present in the live components of the inverter. Prior to performing any work on the inverter, disconnect it from all voltage sources as described in this document.
	WEEE designation Do not dispose of the product together with the household waste but in accordance with the disposal regulations for electronic waste applicable at the installation site.
	Observe the documentations Observe all documentations supplied with the product.
	CE marking The product complies with the requirements of the applicable EU directives.
	Certified safety The product is TUV-tested and complies with the requirements of the EU Equipment and Product Safety Act.
	RCM (Regulatory Compliance Mark) The product complies with the requirements of the applicable Australian standards.
	UKCA marking The product complies with the regulations of the applicable laws of England, Wales and Scotland.

## Symbols on the type label and warning label of the battery

Symbol	Explanation
	Beware of a danger zone This symbol indicates that the battery must be additionally grounded if additional grounding or equipotential bonding is required at the installation site.
	Beware of electrical voltage The product operates at high voltages.
	Corrosive substances warning The product contains corrosive substances that can cause severe injury if they come into direct contact with the skin.
	Potentially explosive substances warning Improper handling or fire can cause the product to ignite or explode.
	Warning of hazards from batteries This symbol indicates the danger of handling batteries.
	Observe the documentations Observe all documentations supplied with the product.
	Refer to the instruction for operation Observe all documentations supplied with the product.
	Use eye protection Wear eye protection for all work on the device.
	No open flame Handling an open flame and sources of ignition is forbidden in the immediate vicinity of the product.
	Access is prohibited for all children Children must be kept at a safe distance from the product.
	Do not short circuit Touching the short-circuit connection of the battery results in death or lethal injuries due to electric shock and massive energy release.
	WEEE designation Do not dispose of the battery together with the household waste but in accordance with the locally applicable disposal regulations for batteries.
	CE marking The product complies with the requirements of the applicable EU directives.
	RCM (Regulatory Compliance Mark) The product complies with the requirements of the applicable Australian standards.

---

	UKCA marking The product complies with the regulations of the applicable laws of England, Wales and Scotland.
UN38.3	Marking for transport of dangerous goods The product passes the certifications of the UN38.3.

### 3. Product Introduction and Application Scenarios

#### 3.1. Naming Convention

## SMILE-G3-S5

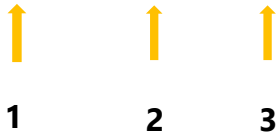

Location	Name	Explanation
1	SMILE	Residential energy storage system
2	G3	Generation 3 for SMILE series
3	S6	Prefix S = Solar Connections (i.e. Hybrid) Prefix B = Battery Only (i.e. AC-coupled) 6kW Inverter with Solar Connections – single phase Hybrid energy storage system
	S5	5kW Inverter with Solar Connections – single phase Hybrid energy storage system
	S3.6	3.6kW Inverter with Solar Connections –single phase Hybrid energy storage system
	B5	5kW Battery-Only inverter – single-phase AC-coupled energy storage system

Complete designation	Designation in this document
SMILE-G3-S6-INV, SMILE-G3-S5-INV, SMILE-G3-S3.6-INV, SMILE-G3-B5-INV	Energy storage inverter
SMILE-G3-BAT-8.2P, SMILE-G3-BAT-10.1P	Parallel batteries
SMILE-G3-BAT-3.6S, SMILE-G3-BAT-3.8S, SMILE-G3-BAT-4.0S	Series batteries
SMILE-G3-S6, SMILE-G3-S5, SMILE-G3-S3.6, SMILE-G3-B5	System/Energy storage system/BESS

### 3.2. System Introduction

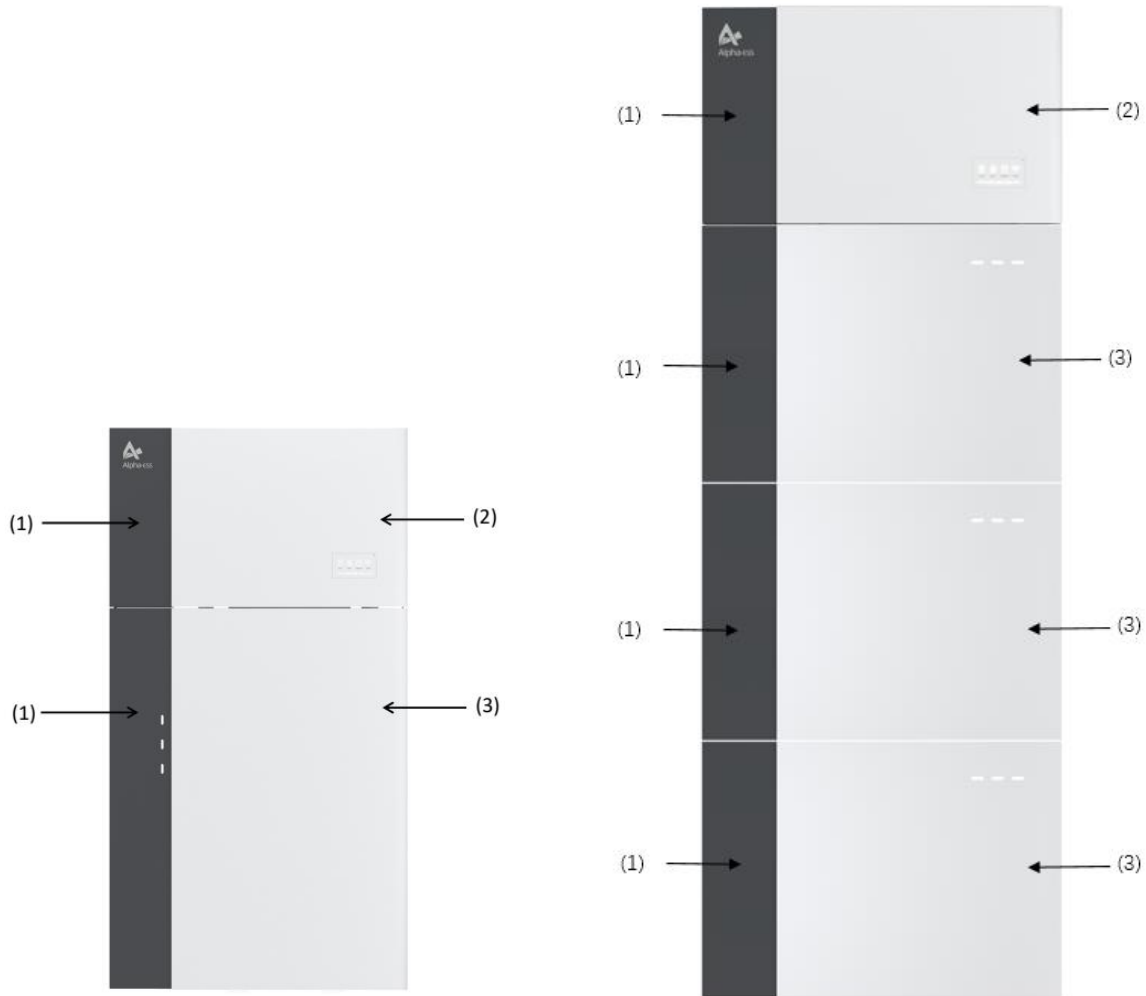

Object	Name	Explanation
1	Cable Cover	Covers for the left wiring area (There are two types of covers, one for the Battery Module(s) wiring and a second for the Inverter connections.)
2	SMILE-G3-S6-INV, SMILE-G3-S5-INV, SMILE-G3-S3.6-INV, SMILE-G3-B5-INV	Energy storage <b>inverter</b>
3	SMILE-G3-BAT-8.2P SMILE-G3-BAT-10.1P SMILE-G3-BAT-3.6S SMILE-G3-BAT-3.8S SMILE-G3-BAT-4.0S	<b>Battery</b>

### 3.3. Product Description

#### 3.3.1. Inverter Electrical Interface & Connections Introduction

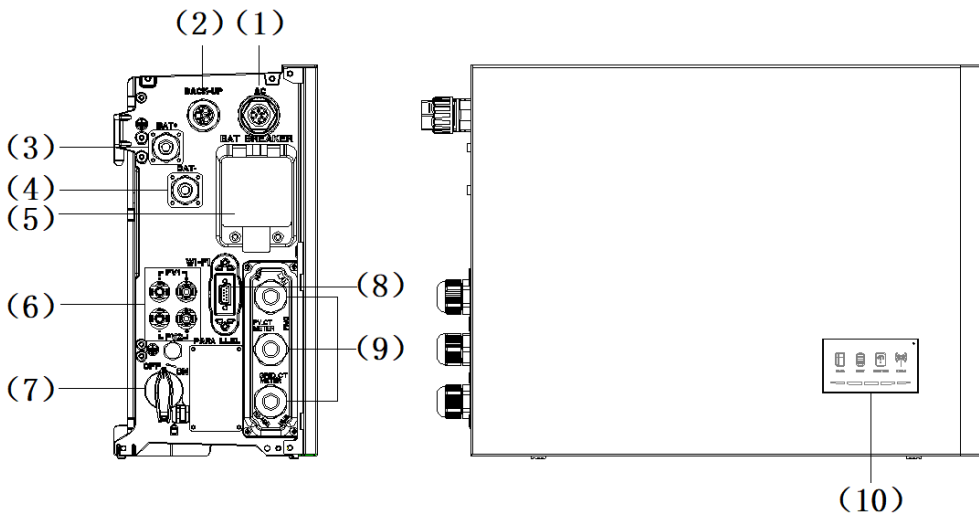

Position	Designation
1	Grid Connector (AC Supply)
2	Backup Connector
3	Battery Positive Cable Connector
4	Battery Negative Cable Connector
5	Battery Breaker of the Inverter
6	Positive and Negative PV Connectors, PV1/ PV2*
7	PV Switch*
8	Wi-Fi Port
9	Communication Ports (BMS, RS485, PV-CT, Meter&Grid-CT, DRM**&RRCR, LAN, AUX)
10	Inverter LED Display

\* For product B5, there are no PV switch and PV inputs.







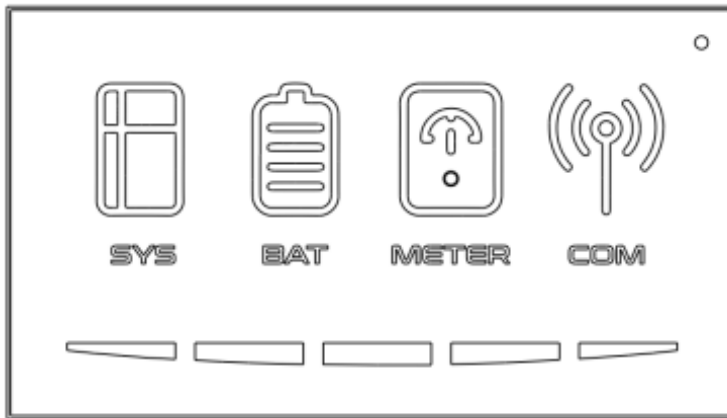

\*\* The DRM is only for regions with AS/NZW 4777.2 safety regulations.

### 3.3.2. Inverter Display Interface Introduction

LED Display



The upper four LED indicators and one reset button are provided on the display panel. These LED indicators provide information about the operation status of the system.

Status	Explanation	Status	Explanation
	<b>White light</b> The system works normally		<b>White light</b> The battery works normally
	<b>Red light</b> The system is in fault		<b>No light</b> The battery is in fault
	<b>White light</b> Meter communication works normally		<b>White light</b> Connected to the server
	<b>No light</b> Meter lost		<b>No light</b> Disconnected to the server

The lower five LED indicators provide information about the State of Charge (SOC) of the batteries connected to this energy storage system.

LED Indicator	SOC	Description
LEDs show the SOC of batteries		$SOC \leq 5\%$
		$5\% < SOC \leq 20\%$
		$20\% < SOC \leq 40\%$
		$40\% < SOC \leq 60\%$
		$60\% < SOC \leq 80\%$
		$80\% < SOC \leq 100\%$

Note that the LED lights provide an approximation of the State of Charge and should be read as an indication and not as a set value.

### 3.3.3. Battery Display Interface Introduction

During normal operation of battery, three LED indicators on the front cover provide information about the SOC of the battery with white lights on and off or flashing (0.5S on, 1.5S off).

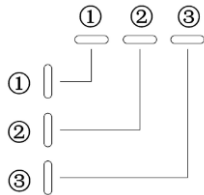

Status	Explanation
	White LED is off.
	White LED is flashing.
	White LED is glowing.

LED Indicator	No.	SOC	Description
LEDs show the SOC status	1		$SOC \leq 10\%$
	2		$10\% < SOC \leq 30\%$
	3		$30\% < SOC \leq 50\%$
	4		$50\% < SOC \leq 60\%$
	5		$60\% < SOC \leq 90\%$
	6		$90\% < SOC \leq 100\%$

#### State Display

The LEDs indicate the operating state of the product.

Standby: all white LEDs are flashing (0.5s on and 0.5s off).

Normal: white LEDs are glowing or flashing (0.5s on and 1.5s off).

Protection: yellow LEDs are glowing or flashing (0.5s on and 0.5s off).

Error: yellow LEDs are glowing or flashing (0.5s on and 0.5s off).

Shutdown: all LEDs are off.

### 3.3.4. Battery Introduction of SMILE-G3-BAT-10.1P

Battery appearance and dimensions

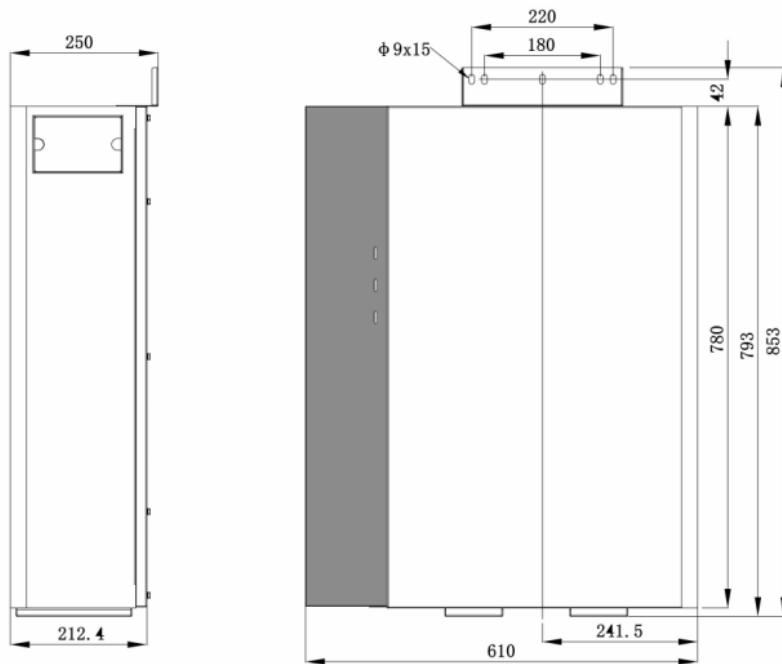

Connection area overview

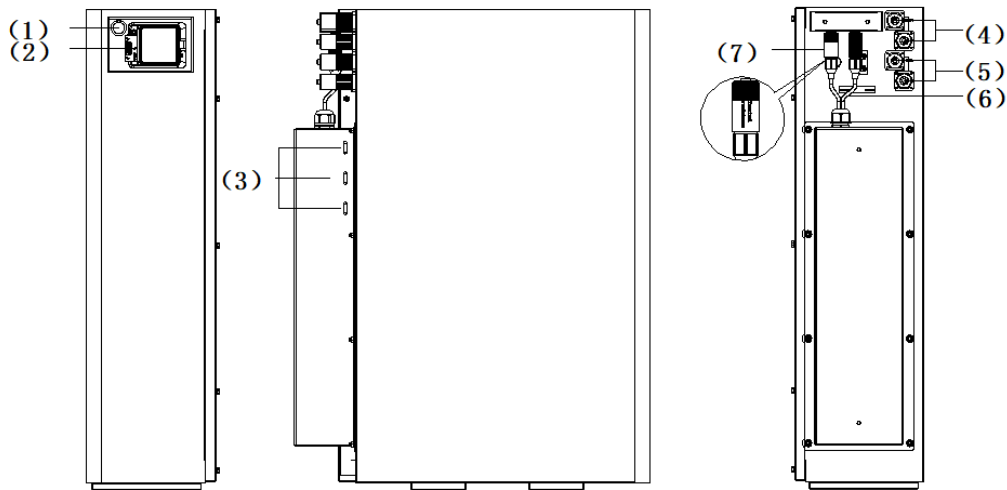

Position	Designation
1	Battery Power Button
2	Battery Breaker
3	Battery LED Display
4	Battery Positive Cable Connector
5	Battery Negative Cable Connector
6	Grounding Point
7	BMS COM Ports: BMS COM1, BMS COM2 (with Terminal Resistor)

### 3.3.5. Battery Introduction of SMILE-G3-BAT-8.2P

Battery appearance and dimensions

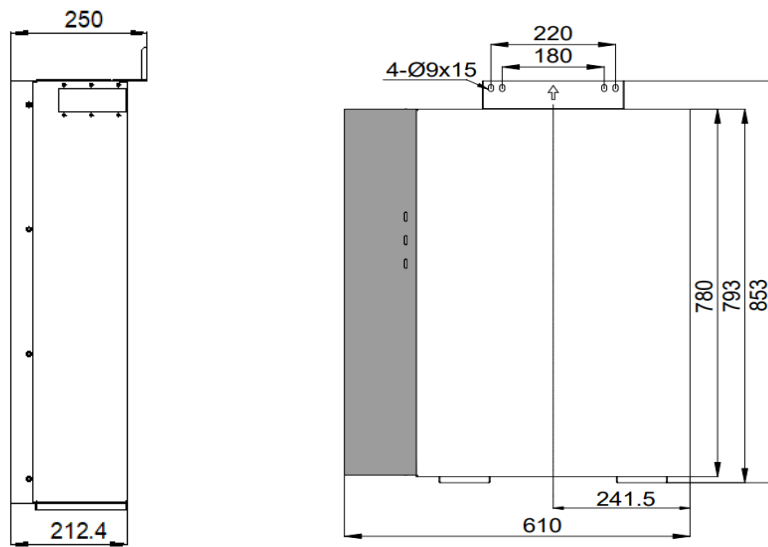

Connection area overview

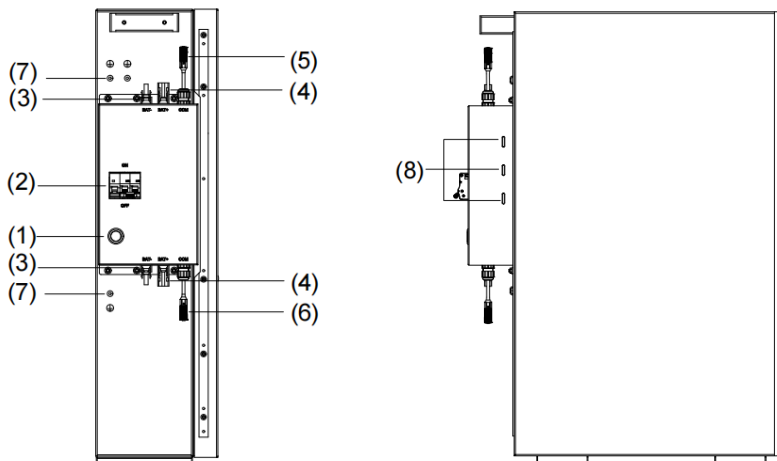

Position	Designation
1	Battery Power Button
2	Battery Breaker
3	Battery Negative Cable Connector
4	Battery Positive Cable Connector
5	BMS COM1
6	BMS COM2 (with Terminal Resistor)
7	Grounding Point
8	Battery LED Display

### 3.3.6. Battery Introduction of SMILE-G3-BAT-3.6S/4.0S

Battery appearance and Dimensions

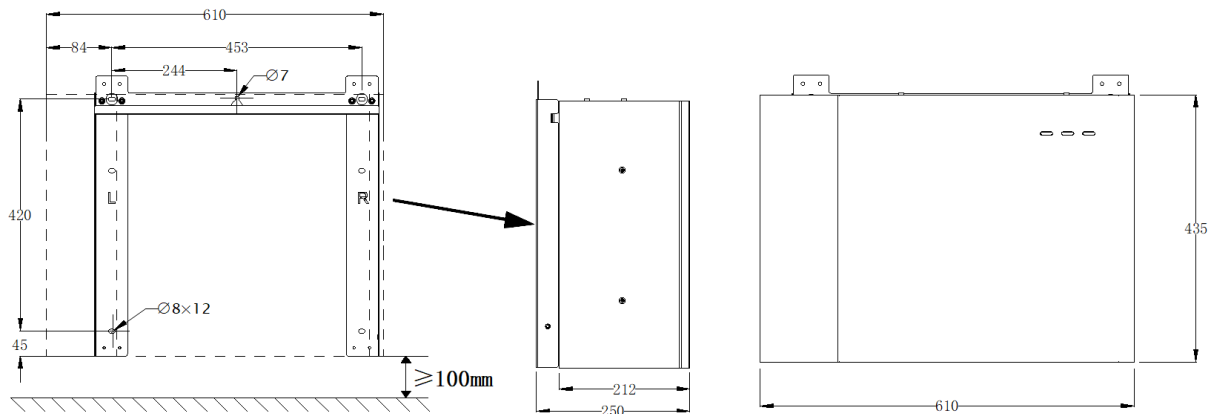

Connection area overview

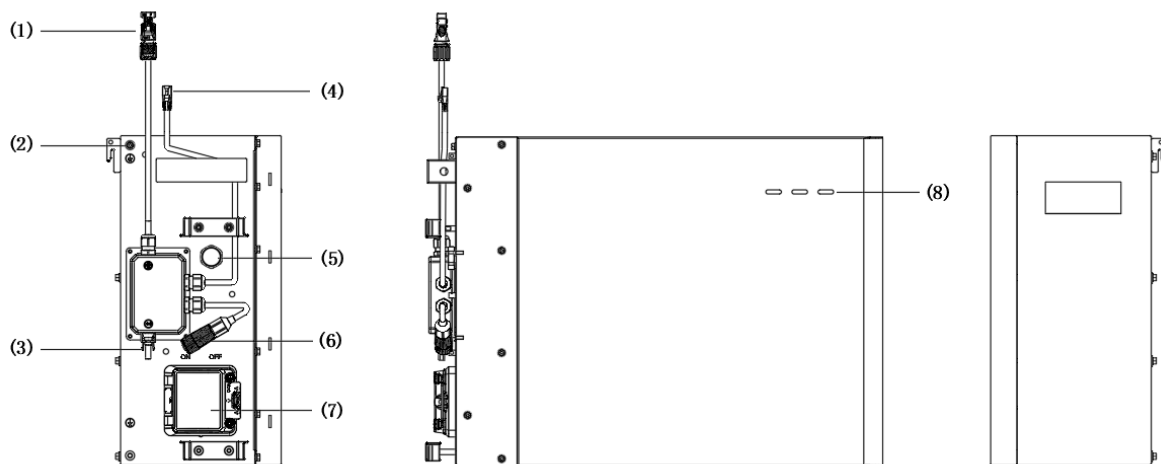

Position	Designation
1	Battery Positive Cable Connector
2	Grounding Point
3	Battery Negative Cable Connector
4	BMS COM1
5	Pressure Relief Valve
6	BMS COM2 (with Terminal Resistor)
7	Battery Circuit Breaker
8	LED Display

### 3.3.7. Battery Introduction of SMILE-G3-BAT-3.8S

Battery appearance and dimensions

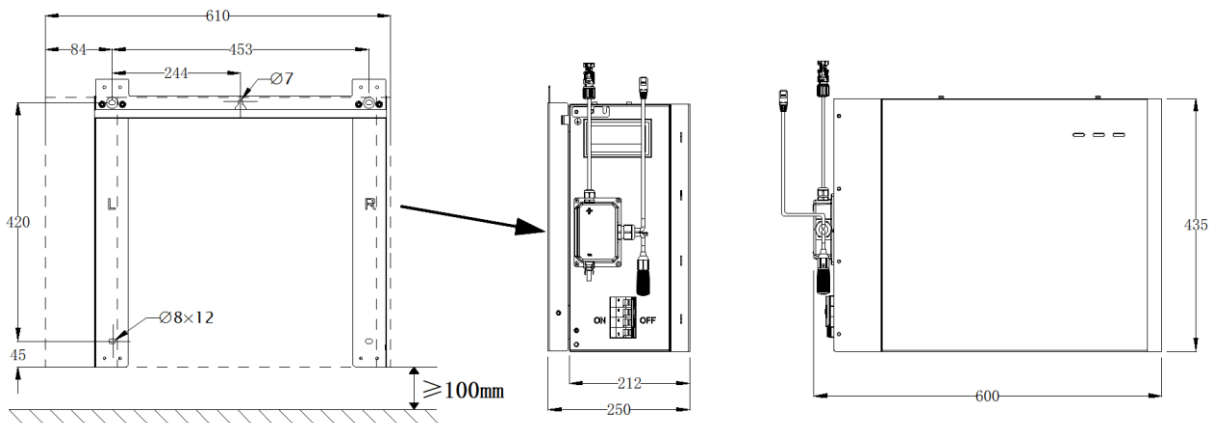

Connection area overview

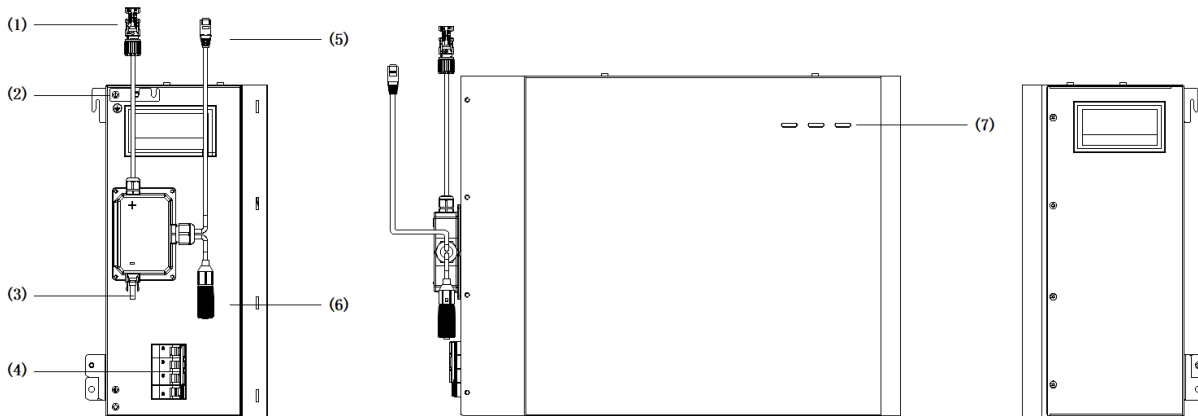

Position	Designation
1	Battery Positive Cable Connector
2	Grounding Point
3	Battery Negative Cable Connector
4	Battery Circuit Breaker
5	BMS COM1
6	BMS COM2 (with Terminal Resistor)
7	Battery LED Display

### 3.4. Application Scenarios

SMILE-G3 single phase system (comprise of the inverter SMILE-G3-S6/S5/S3.6/B5-INV and battery SMILE-G3-BAT-10.1P, SMILE-G3-BAT-8.2P, SMILE-G3-BAT-3.6S/3.8S/4.0S) can be connected as a DC-Coupled systems (mostly new installation), AC-Coupled systems (mostly retrofit), Hybrid-Coupled systems (mostly retrofit, and increase the PV capacity), and Off-Grid (with Generator) systems as shown in the following diagrams:

#### 3.4.1. DC-Coupled Storage System

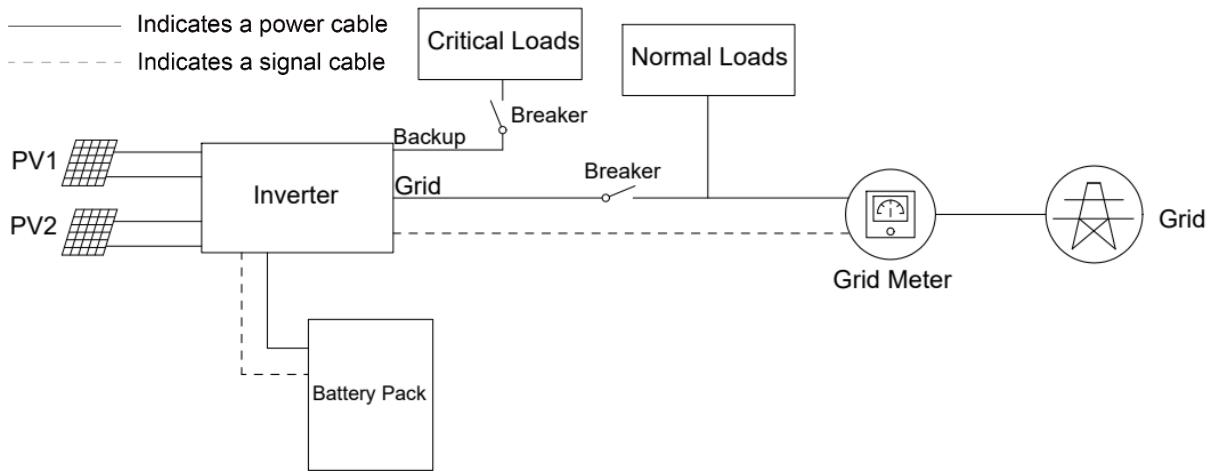

DC-Coupled Storage System – Scheme

#### 3.4.2. AC-Coupled Storage System

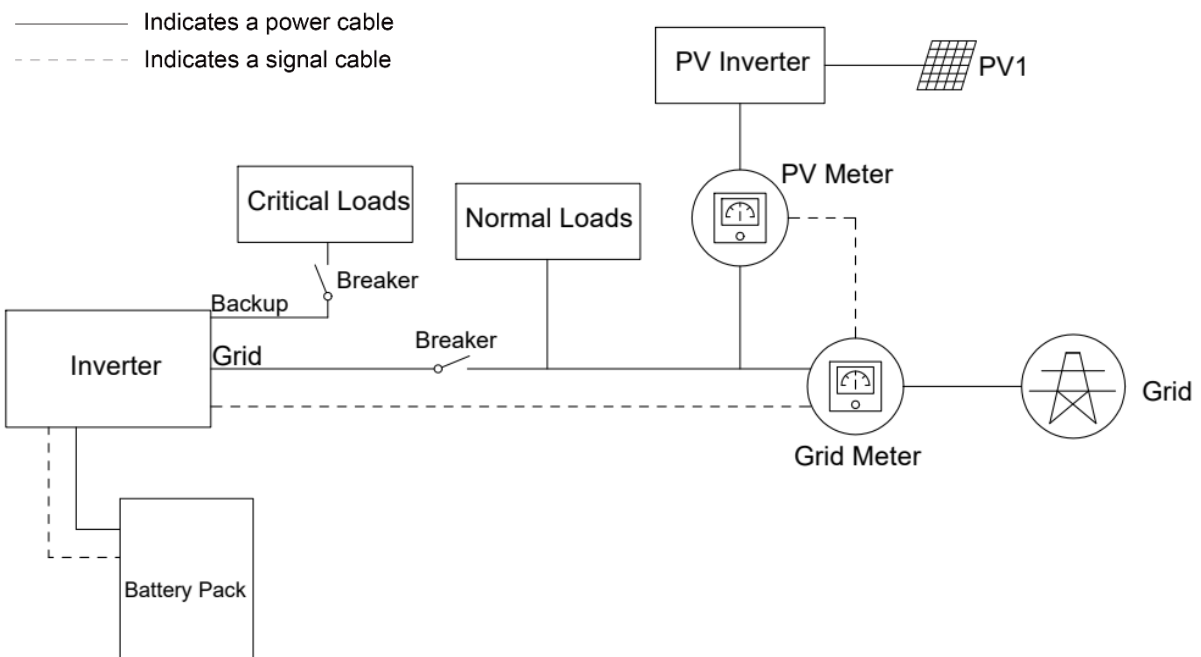

AC-Coupled Storage System – Scheme

### 3.4.3. Hybrid-Coupled Storage System

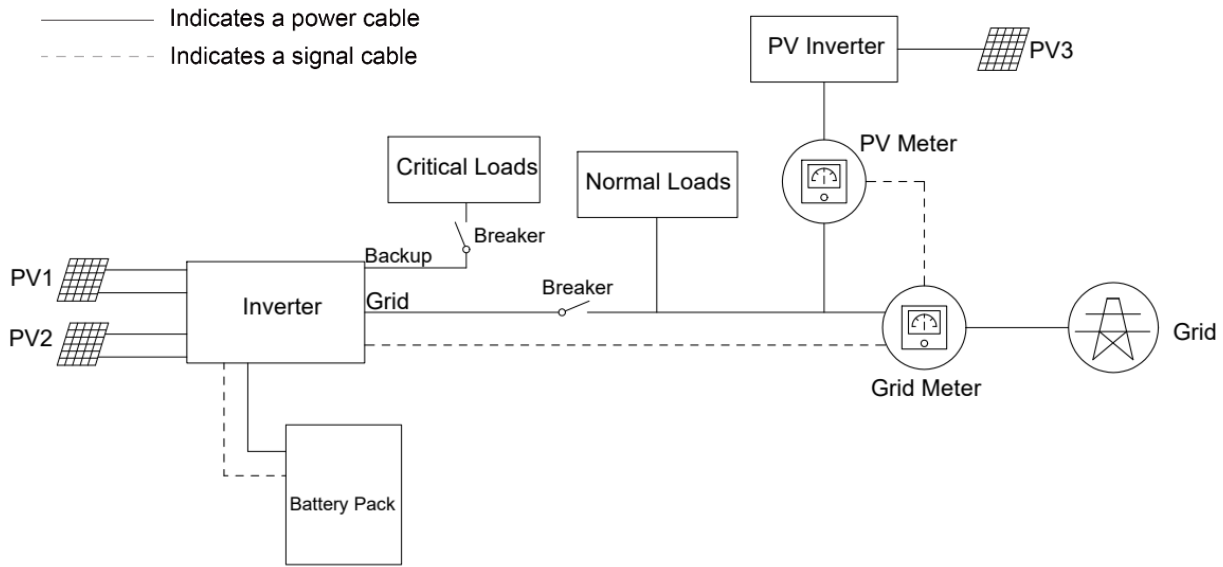

Hybrid-Coupled Storage System – Scheme

### 3.4.4. Off-Grid Storage System

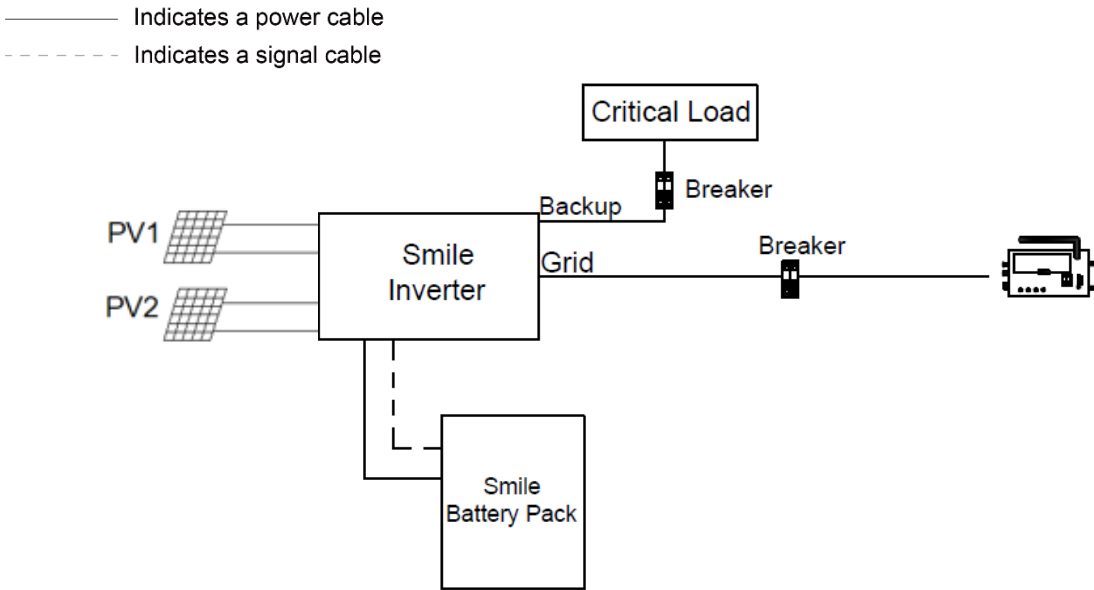

Off-Grid (with Generator) Storage System – Scheme

NOTE: In all cases, Normal Loads and Essential Loads must be appropriately protected by earth fault protection devices (e.g. Type A or Type B RCDs, RCBOs) in accordance with appropriate Standards. Backup/Essential Loads should not exceed the rated capacity of the inverter, even during on-grid operation.

## 4. Power on and off the System

### 4.1. Power on the System

- 1) Switch on the battery circuit breaker which is at the upper left of the inverter.
- 2) Switch on the battery circuit breakers of all batteries.
- 3) For series batteries, please skip this step.

Shortly press the power buttons of all parallel batteries. For more than one parallel battery installed, please press all power buttons within 30 seconds. This power button is located just beside the battery circuit breaker on each parallel battery.

- 4) Switch on the AC circuit breaker between the grid port of the energy storage inverter and the mains grid (this AC circuit breaker should be labelled Main Switch Battery ESS Supply or similar).
- 5) Switch on the AC circuit breaker between the backup port of the energy storage inverter and the loads (this AC circuit breaker should be labelled Main Switch Battery ESS Backup or similar).
- 6) Switch on the PV switch at the lower left of the inverter (if there are PV strings directly connected to the energy storage inverter).
- 7) Switch on the AC circuit breaker (if there is any) between any separate PV inverter and the mains grid. These separate PV inverters are also referred to as "AC-coupled PV inverters".

## 4.2. Power off the System

 **WARNING**

After the energy storage system is powered off, the remaining electricity and heat may still cause electric shocks and body burns. Please put on protective gloves and operate the product 5 minutes after the system is powered off.

- 1) Switch off the AC circuit breaker between the energy storage inverter and the backed-up loads.
- 2) Switch off the PV DC Isolator(s) between the PV strings and the energy storage inverter if there are any.
- 3) Switch off the PV switch on the lower left of the energy storage inverter (if there are PV strings directly connected the energy storage inverter).
- 4) For series batteries, please skip this step.  
Hold the battery power button located beside the battery circuit breaker for 6s to turn off each parallel battery.
- 5) Switch off the battery circuit breakers of all batteries.
- 6) Switch off the battery circuit breaker which is at the upper left of the inverter.
- 7) Switch off the AC circuit breaker between the energy storage inverter and the mains grid.

## 5. Operation

### 5.1. Monitor System on AlphaESS APP

#### 5.1.1. Download and Install the App

1. Android device users can download the App through major Android App stores such as Google Play.
2. IOS device users can search for "AlphaESS" in the App Store and download the App.



AlphaESS App

#### 5.1.2. Register as an End User

If you don't have an end user account, please register first.

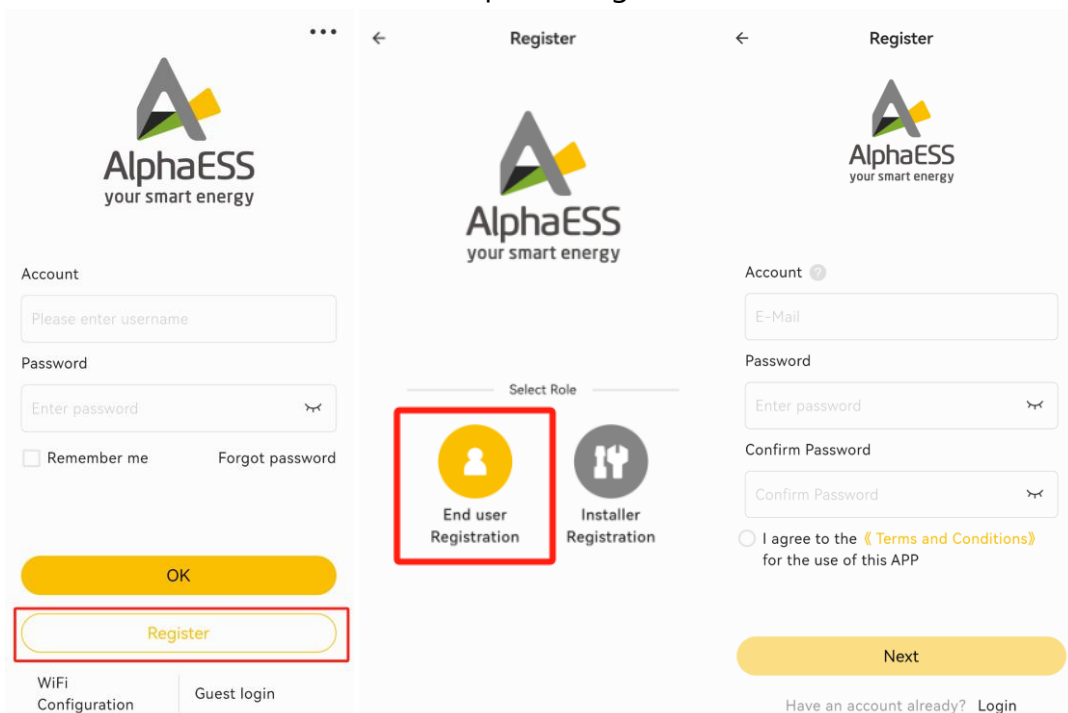

If you already have an end user account, please log in directly.

Then you can enjoy your system monitoring on AlphaESS APP.

## 5.2. Monitor System on AlphaCloud

### 5.2.1. Register an End User Account on AlphaCloud

If you don't have an end user account, you can create a new account on our web server for system monitoring purposes.

The data produced prior to registration can be synchronized to the web server.

**Step 1:** Please open the portal: <https://cloud.alphaess.com>.

**Step 2:** Please fill in "Username", "Password" and click "Login" if you have already registered.

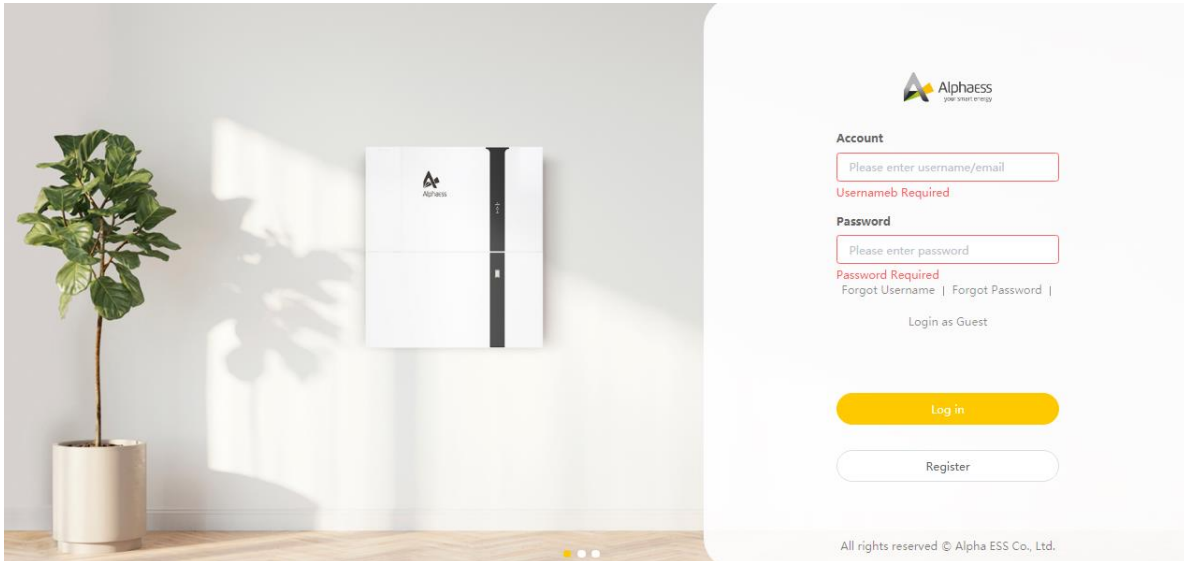

If not, please register by filling in the following web form.



### 5.3. Reconfigure Network

Your system would be offline, when unable to monitor the device, if you recently changed router network operator or changed Wi-Fi password.

To make your device on line, you can click the rolling information on the top of APP, and follow the guide to reconfigure network.

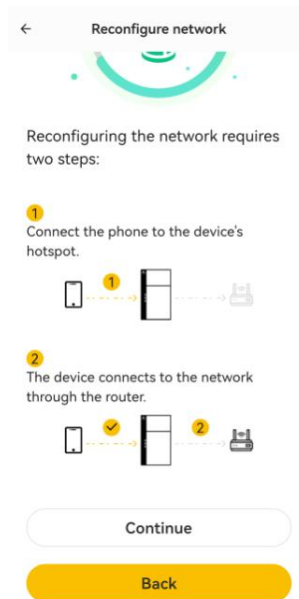
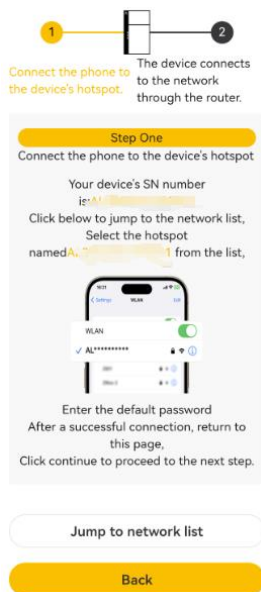
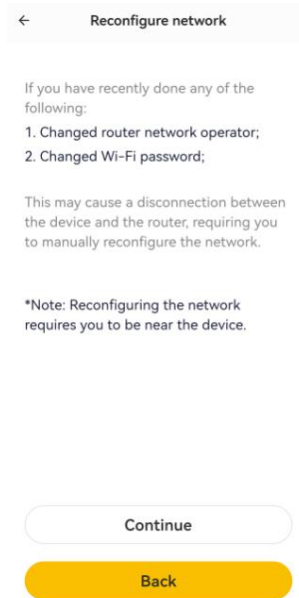
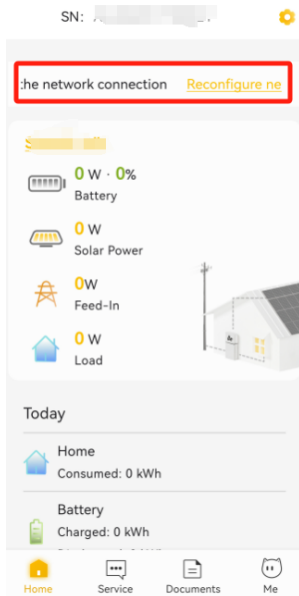

## 6. Maintenance

### 6.1. Routine Maintenance

Normally, the energy storage system needs no maintenance or calibration. However, in order to maintain the accuracy of the SOC, it is recommended to perform a full charge calibration for SOC (charge the battery until the charge power is 0W) on the battery at regular intervals (such as two weeks).

Before cleaning, ensure that the system is disconnected from all power sources. Clean the housing, cover and display panel with a soft cloth.

To ensure that the energy storage system can operate properly in the long term, it is advised to perform routine maintenance as described in this chapter.

#### Maintenance checklist

Check Item	Acceptance Criteria	Maintenance Interval
Product cleanliness	The enclosure of the inverter should be free from obstacles or dust.	Once every 6 to 12 months
Product visible damage	The product should be not damaged or deformed.	Once every 6 months
Product running status	1. The product should operate without any abnormal sound. 2. All parameters of the product should be set correctly. Perform this check when the product is running.	Once every 6 months
Electrical connections	1. Cables should be securely connected. 2. Cables should be intact, and in particular, the cable jackets touching the metallic surface should not be scratched. 3. Unused cable glands should be blocked by rubber sealing which are secured by pressure caps.	Perform the first maintenance 6 months after the initial commissioning. Thereafter, perform the maintenance once every 6 to 12 months.

**CAUTION**

**Risk of burns due to hot enclosure of the inverter**

The enclosure of the inverter can get hot during operation.

- Do not touch any parts other than the display panel during operation.
- Wait approximately 30 minutes for the inverter to cool down before cleaning.

## 7. Product Removal & Return

### 7.1. Removing the Product

#### Procedure

- Step 1: Power off the energy storage system as described in Chapter 4.2 Powering off the System.
- Step 2: Disconnect all cables from the system, including communication cables, PV power cables, battery power cables, AC cables, and PE cables.
- Step 3: Remove the Wi-Fi module.
- Step 4: Remove the cable covers of the inverter and the battery.  
Remove the top cover and right cover of the inverter.
- Step 5: Remove the inverter from the top of the battery.
- Step 6: Remove the battery wall brackets.
- Step 7: Remove the batteries.

### 7.2. Packing the Product

If the original packaging is available, put the product inside it and then seal it using adhesive tape.

If the original packaging is not available, put the product inside a suitable cardboard box and seal it properly.

### 7.3. Disposing of the Product

- If the product service life expires, dispose of it according to the local disposal rules for electrical equipment and electronic waste.
- Dispose of the packaging and replaced parts according to the rules at the installation site where the device is installed.
- Do not dispose the product with regular household waste.

